

# SONY®

# ROBO KIDS

Sony Desktop Robot

## OPERATION MANUAL

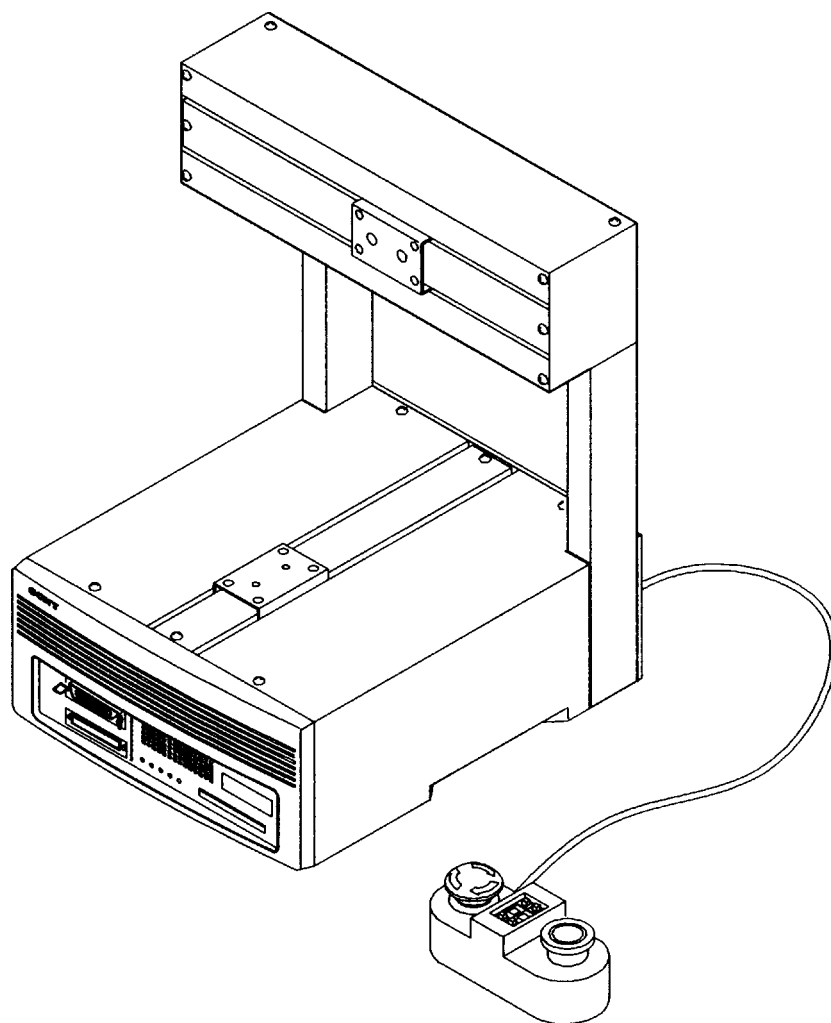

## About this Operation Manual

This Operation Manual is intended as a guide for users of the Sony Desktop Robot ROBOKIDS.

Before operating this system, you should first thoroughly read this manual. You may not understand all of the explanations the first time through, but be on the lookout for any special directions.

It should be used in conjunction with the RK card manual for your specifications.

- This manual may not be replicated in whole or in part without the prior written authorization of Sony Corporation.
- The information described herein is subject to change without notice.
- The information described herein has been checked for both reliability and accuracy. However, if you have any questions, or notice any errors or omissions in this manual, please contact the following offices of Sony Corporation.

### **[Singapore]**

**Sony Electronics (Singapore) Pte. Ltd**

SPEC, No.52 Tuas Avenue 9, Singapore 639193

TEL : 8615858

FAX : 8621521

### **[Europe]**

**Sony Wega Produktions GmbH**

**Production Technology Division Europe**

Hedelfinger Str. 61

D-70327 Stuttgart Germany

TEL : +49 (0)711 5858-420

FAX : +49 (0)711 574153

### **[Japan]**

**Sony Manufacturing Systems Corporation**

**FA Service Department**

1-10, Kiyoku-cho, Kuki-shi

Saitama, 346-0035 JAPAN

TEL : 0480-23-1956

FAX : 0480-23-1706

# How to Use this Operation Manual

## **First Time Users**

Read this manual from chapter 1 through chapter 4 before starting any operation. The manual describes the procedures required in setting up ROBOKIDS for users who have little experience with FA (Factory Automation) equipment.

## **Routine Assembly**

Follow the respective application manuals for routine assembly task operations.

## **Replacing the Unit or Memory Card**

Remove the existing unit. Attach the new unit and replace the memory card. References of the memory card may be found in this Operation manual or the respective application manuals.

This manual describes the ROBOKIDS base machine. Details for application unit installations may be found in the operation manuals that are attached when purchasing the application units.

# Manual Configuration

This operation manual describes the procedures required to operate the desktop robot ROBOKIDS. Various types of applications such as dispensing and soldering may be accomplished by exchanging the memory cards (RK card) which stores the programs required to run an application. The semi-programmable specification allows the user to modify an operation program and peripheral task program to perform a specific work. The full open programmable specification enables the user to freely write any program to perform a unique application. This manual contains the common contents between dispensing, soldering, semi-programmable and the full open programmable specification. For further details refer to the memory card (RK Card) operation manual (or the Full Open Programmable operation manual for the full open programmable specifications.)

## Safety Instruction

Describes the safety precautions for user's safety.

## Unpacking

Describes the precautions during unpacking, and lists the supplied accessories.

### 1. Outline

Outlines features, names and functions of controls, and its specifications.

### 2. Preparation

Helps you set up the base machine. Beside the supplied accessories, you also may need to purchase the dispensing unit, soldering unit, air compressor, workpiece fixing tool (including fixing screws) depending on the configuration.

### 3. Maintenance

Describes daily maintenance.

### 4. Troubleshooting

Describes countermeasure (only the contents which are in common in applications) when an error occurs during operation. The Operation Manual of each memory card (RK card) describes countermeasures for dispensing errors and soldering errors.

### 5. Replacement Parts

Shows list of main replacement parts of the base machine.

### 6. Appendix

Described input and output specifications of each connector.

# Contents

<b>Safety Instruction .....</b>	<b>S-1</b>
<b>Unpacking .....</b>	<b>U-1</b>
<b>1. Outline</b>	
1-1 Nomenclature .....	1-2
1-2 Outline Drawings .....	1-4
1-3 Specifications .....	1-9
1-3-1 Machine Specification .....	1-9
1-3-2 Control Specifications .....	1-10
<b>2. Preparation</b>	
2-1 Attaching the Units .....	2-1
2-1-1 Attaching the Z-unit .....	2-1
2-1-2 Attaching the ZR-unit .....	2-4
2-2 Connecting the External Signal .....	2-7
2-3 Connecting to an Electrical Outlet .....	2-12
2-4 Starting Up the Base Machine .....	2-13
2-4-1 Full-open Programmable Specification .....	2-13
2-4-2 When Using Memory Card “RK card” .....	2-13
<b>3. Maintenance</b>	
3-1 Maintaining the Machine .....	3-1
3-2 Greasing the Machine and Removing Fallen Materials .....	3-1
3-3 Cleaning and Replacing the Air Filter .....	3-4
3-4 Replacing the Battery .....	3-6
<b>4. Troubleshooting</b>	
4-1 Common Items .....	4-1
4-1-1 Stepping Out .....	4-1
4-1-2 External Noise .....	4-3
4-1-3 Abnormal Sound from Unit’s Motors .....	4-3
4-2 Full-open Programmable Specifications .....	4-4
4-3 When Memory Card (RK Card) is Used .....	4-7
Trouble Check Sheet .....	4-10
<b>5. Repair Parts Lists</b>	
5-1 ROBOKIDS Body .....	5-1
5-2 Z-axis Unit .....	5-1
5-3 ZR-axis Unit .....	5-2
<b>6. Appendix .....</b>	<b>6-1</b>

# Safety Instruction

Sony Corporation designs and manufactures all its equipment with strict attention to safety. However, if the machine is operated or maintained without regard to the safety guidelines, damage or injury to the machine or operator may occur.

To prevent accidents, those in charge of operation and maintenance must follow the safety work rules when using the machine. Always read the safety precautions carefully before reading the Operation Manual, and carefully note the following safety rules.

Observe all precautions to ensure safety.

Read the precautions on pages 3 to 6 thoroughly.

Perform regular inspections.

Inspect the machine referring to chapter “3. Maintenance”.

In the event of accidents....

Consult with the dealer that is indicated on warranty card after filling in the trouble check sheet which is attached to the end of the Operation Manual.

## Definition of warning symbols

Pay particular attention to the following symbols and conventions shown on the machine and on the Operation Manual. Fully understand the contents of symbols and conventions before reading the Operation Manual.

### 《Machine Symbols》



Indicates a protective terminal of mechanical parts to which an external protective earth wire is connected.



When the part with this mark is removed, the high voltage appears.



Check the operation manual before using the part with this mark.



Be cautious not to pinch your hands or fingers into the units moving parts. Before you perform any maintenance and/or check, disconnect the unit from the main power supply.

### 《Operation Manual Symbols》



Indicates that mis-operations or mis-handling may result in unexpected danger (fire, etc.,) and the that operator is at risk (of major injury).



Indicates that mis-handling may result in unexpected danger (electric shock, etc.,) and that the operator is at risk of injury or the equipment at risk of damage.

## ■ Important Safeguards



- ◆ *The tool driving mechanism are subject to unexpected movement. Pay attention to safety measures.*
- ◆ *Turn off the main power prior to performing maintenance or inspections. Failure to observe this may result in severe injury through electric shocks or unexpected movement of the machine.*
- ◆ *Mistakes during maintenance and inspections may result in accidents. Observe the followings prior to starting maintenance or inspections:*
  1. *Read the Operation Manual thoroughly and following all instructions and warnings closely.*
  2. *Implement inspections on a daily basis to prevent accidents arising from damaged equipment.*
  3. *Pay attention so that the power cord is not pinched by the machine and the peripheral equipment when installing the machine system.*
- ◆ *Ensure to connect the primary power supply to the three-pin AC power outlet using the power cord (supplied with earth wire) supplied with the equipment. Electrical potential difference will occur with surrounding equipment if the electrical earth is not connected and may result in electrical leakage or electrical shocks.*



- ◆ *Heavy object. Move and transport with two or more persons, and pay attention to safety measures.*
- ◆ *To maintain safety do not make any modifications to the equipment in order.*
- ◆ *Be careful so that hands must not be pinched by the movable blocks. (Movable parts of each axis, tool attachment block, table block, belt beneath the units, tools, works, etc.)*
- ◆ *Avoid installing in the following locations:*
  - In places which receive direct sunlight or which experience temperature ranges exceeding 0 degrees °C and 40 degrees °C.*
  - In places which experience relative humidity ranges exceeding 35% and 90%, and places in which condensation is generated by rapidly changing humidity.*
  - In places where corrosive gas or inflammable gas exists.*
  - In places where the unit will be subject to direct vibrations or impact.*
  - Close to machinery which emits electrical noise, such as welders, electric dischargers or high-frequency generators.*
  - In places where any obstacles are anticipated during maintenance and inspection.*
- ◆ *Precautions during operation, movement, maintenance and inspection*
  - During operation the machine may look as if it has stopped. Be careful when certain conditions are met, the machine will resume motion automatically.*
- ◆ *Connect the earth wiring (FG) to the tools.*
  - Electrical potential difference will occur with surrounding equipment if the electrical earth is not connected and may result in electrical shocks.*
- ◆ *Be careful that motor gets very hot.*





## **Precautions on Usage**

---

### **Operate on the specified voltage**

Operate the ROBOKIDS only on AC power voltage as specified on the label of the machine. The power cord must be directly connected to the electrical output, and grounded. The ROBOKIDS conforms with the safety requirements of the target country to which it is shipped.

### **When a machine will not be used for extended period of time**

If the machine is not in use for a long period, unplug the power cord from the electrical output. To unplug, pull on the plug. Never pull on the cord.

### **Do not drop any foreign material into the machine**

Dropping any flammable liquid or metal, object into the machine can cause errors and trouble of the machine. Should any of them drop into the machine, unplug the power cord and contact your local Sony dealer.

### **Do not place any obstacles in front of the fans.**

Heat dissipation will be insufficient and the accumulated heat can cause malfunctions.

## **Precautions on Transportation**

---

- Avoid excessive shock. Excessive shock such as dropping the machine may cause damage.
- Do not hit the units or work table during operation. Also be careful so that hands and/or clothes are not pinched by the machine. It can cause unexpected physical injury.
- Be sure to hold the bottom panel when moving the machine.

## Precaution on memory cards

---

Before inserting or removing a memory card, always turn the power off.

The data stored in the memory card may be damaged if a memory card is inserted or removed while the power is on.

## Precaution on the teaching pendant

---

ROBOKIDS uses a teaching pendant for the CAST-PRO or SRX. The CAST-U teaching pendant and CAST-PRO teaching pendant are not compatible. Do not use the CAST-U teaching pendant with the ROBOKIDS.



*If the CAST-U teaching pendant is used with the ROBOKIDS., the ROBOKIDS cannot exit the emergency stop state and can be damaged. Do not use the CAST-U teaching pendant with the ROBOKIDS.*

*If the SRX teaching pendant (SRX-P006) is used with the ROBOKIDS. the ROBOKIDS can be damaged. Do not use the SRX teaching pendant with the ROBOKIDS.*

## Precaution on maintenance

---

Periodic inspection of the following items is recommended once every six months.

### Operation check of the fan attached to the controller

Be sure to check the operation of the fan attached to the controller before starting operation.

Equipment can be seriously damaged by heat accumulated in ICs in certain operating environments in which equipment is used without sufficient heat dissipation.

## On handling batteries

The following battery is used in the base machine controller.

Lithium battery (primary battery) of type : CR17335SE-CN21 Manufactured by Sanyo Electric Co.

*Incorrect handling of the battery may result in dangerous situation.*

*Do not perform the actions as listed below for safety. Sony Corporation is not responsible for the troubles related to the operation of the following precautions.*

*(1) Shorting*

*Do not short the batteries.*

*Shorting the battery may damage the equipment or may result in thermal injury due to overheating.*

*(2) Disassembling*

*Do not disassemble the batteries.*

*Gas will be generated irritating the throat. Lithium metal may be generated. The batteries can be heated internally resulting in explosion or fire if the batteries are subject to shock.*

*(3) Throwing into fire or water*

*The battery may explode, generate fire due to liquid leakage or internal shorting if the battery is heated. Never throw the battery into fire. The batteries can explode if they are thrown into fire. Throwing the batteries into water may lose the battery function.*

*(4) Soldering*

*Do not make any soldering directly to the batteries. The batteries can explode or generate fire due to liquid leakage or internal shorting inside the batteries caused by heat.*

*(5) Do not connect the batteries with reverse polarities between (+) and (-)*

*(6) Using the batteries for other applications*

*Do not use the batteries for other applications. The batteries may be damaged or the equipment can be damaged due to specification differences.*

*(7) Charging*

*Do not charge the lithium battery (primary battery). Gas will be generated inside causing explosion and fire.*



## Life and replacement of batteries

The nominal life of the lithium battery (primary battery) used in the controller is 3 to 5 years. Replace it every 3 years as a guide line. (Refer to section “3-4 Replacing the Battery” for the replacement procedure.)

Life, however, can be shorter than the nominal life depending upon the ambient environments.

The front POWER indicator changes from green to red when a battery runs out.

# Unpacking



*Transport it to the installation position while taking care not to drop or fall. Pay extra attention not to give any vibration or shock because the controller contains precision electronic parts.*

**NOTE**

*Be sure to use the packaging material specified by Sony Corporation when transporting the machine.*

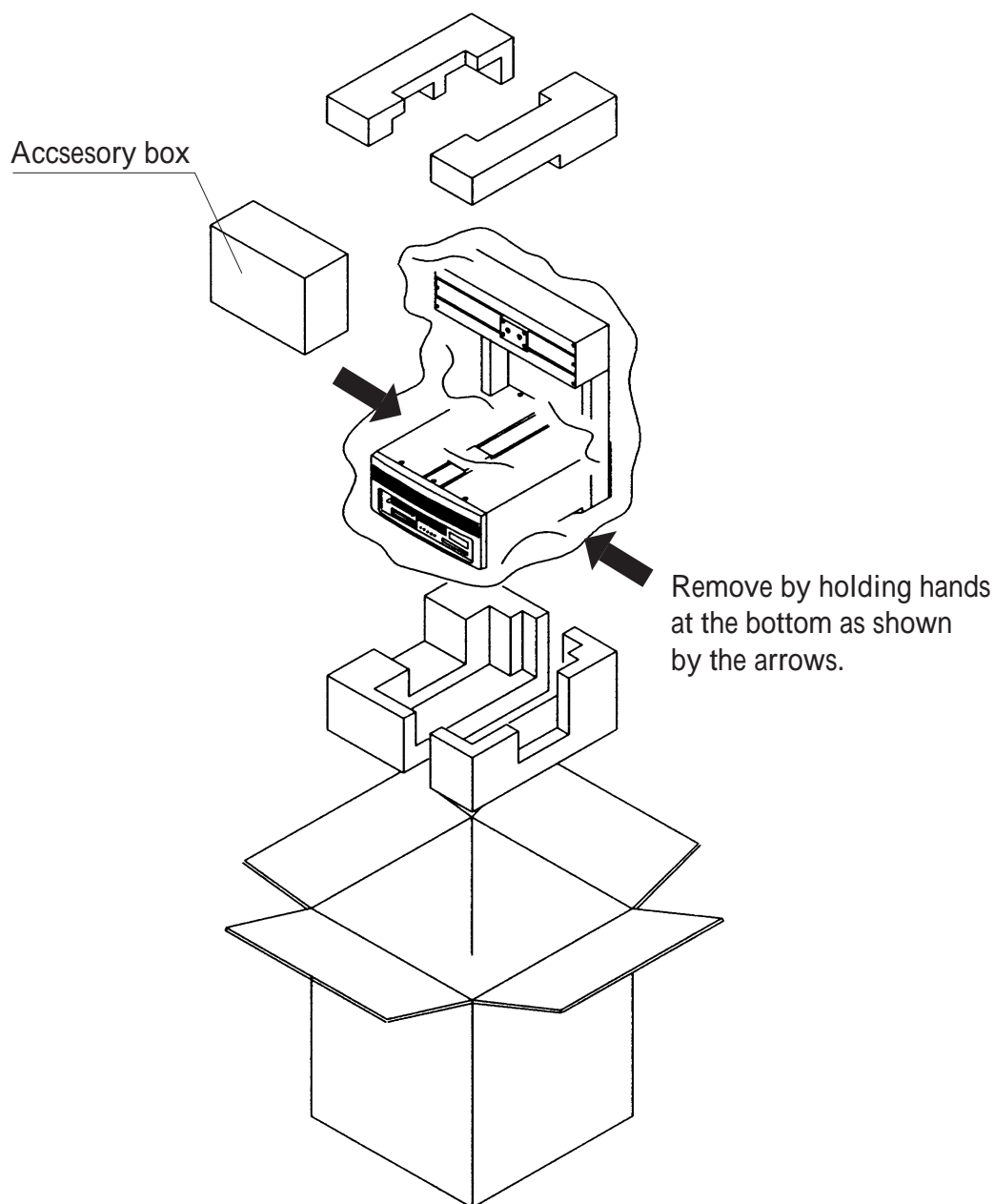

When the machine is unpacked, make sure the following items are in the package.

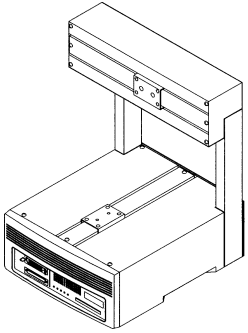

Base machine

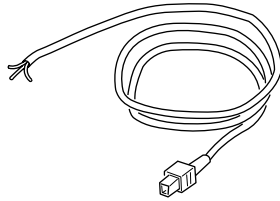

Power cable  
(For AC 200V to 240 V)

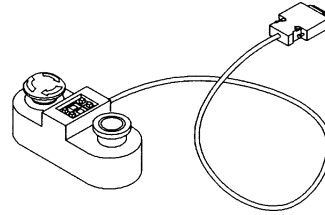

Operation box

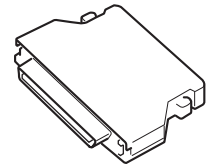

USER I/O connector  
PCR-E68FS (connector)  
PCS-E68LA (connector cover)  
(Honda Communications Company)

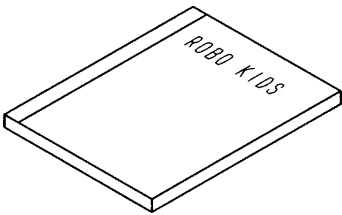

Operation Manual

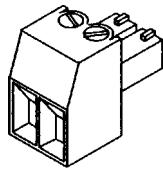

External supply power  
connector for USER I/O  
MC 1.5/2-ST-3.81  
(Phoenix Contact Inc.)

# 1. Outline

ROBOKIDS is a desktop assembly tool designed to automate cell production systems saving a significant amount of power consumed by assembly lines. It may be used in a variety of applications by simply exchanging the work unit and memory card. The basic operation procedures are common throughout the applications enabling a smooth migration from one work to another.

- The programs required for an application are stored in the memory card “RK Card”. Operation is started by inserting the specific memory card into the base machine and teaching the work points. The machine may be switched to perform a different application by exchanging the memory card.
- The work points and the working speed may be set by using the simple operation teaching pendant (option) even by someone who has just purchased ROBOKIDS.
- The power supply and controller are built inside the machine thus making the system transportable to the place where it is needed.
- The machine is equipped with an external switch connector and also an USER I/O connector allowing synchronous operation with external equipment. Remote operation is also possible.

**NOTE**

*The external switch and connector enabling operation of the machine by two operators, must be prepared by the user.*

## ■ Product Configuration

The base machine consists of two axes X-axis and Y-axis. It may be upgraded to three and four axes by installing the optional Z-unit and ZR-unit respectively.

## 1-1 Nomenclature

### Front View

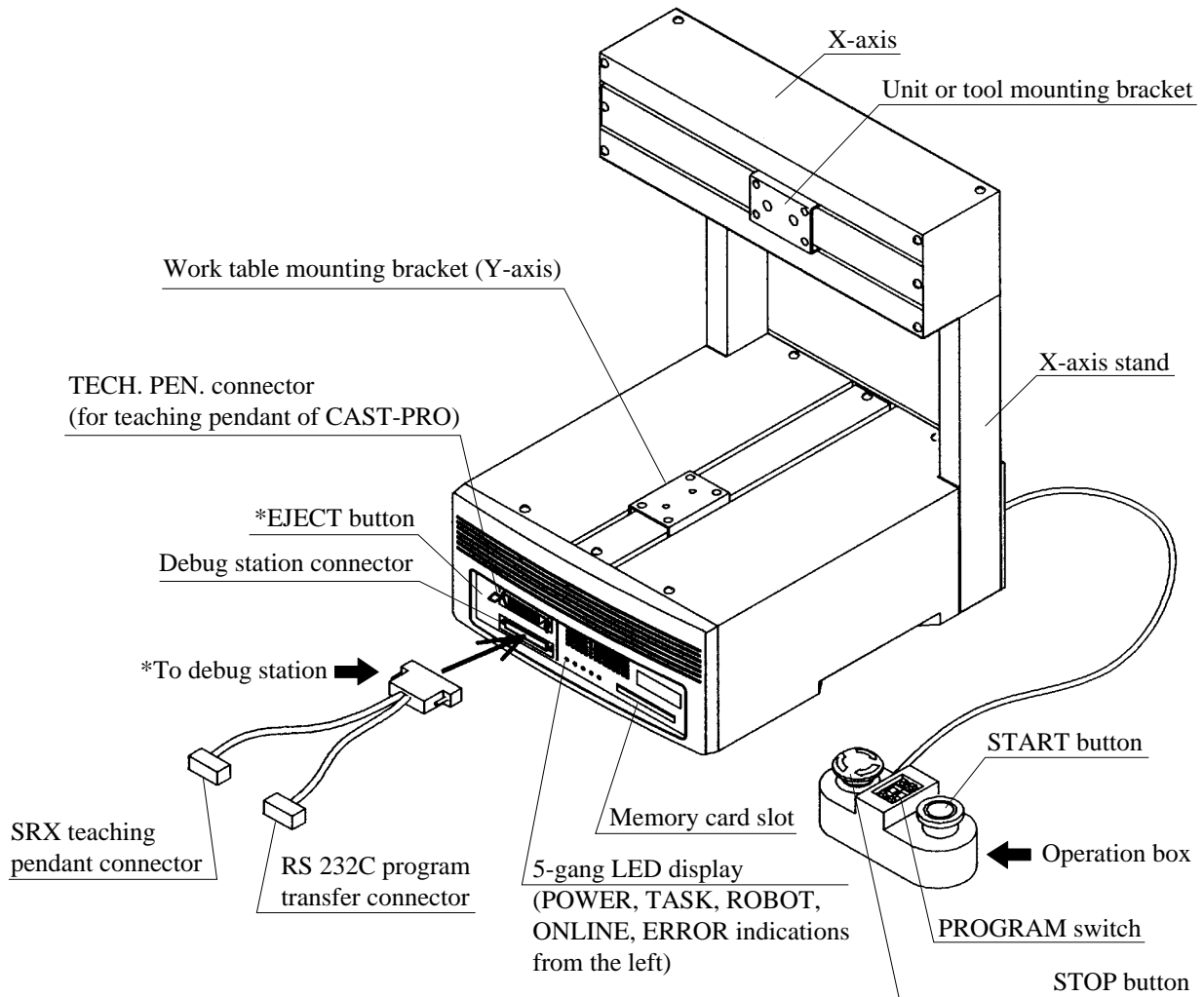

#### \* Debug station ••• Option

Either the “SRX teaching pendant” or the program transfer cable can be directly connected to the debug station connector.

\* EJECT button ••• When inserting or removing the CAST-PRO teaching pendant, insert it or remove it while pressing the EJECT button.

### 5-gang LED Display

The following machine conditions are indicated on the 5-gang LED display.

1. ERROR .....Illuminates during the error state.
2. ONLINE .....Illuminates during the on-line state. (Illuminates normally.)
3. ROBOT .....Illuminates while the servo is on. (Illuminates continually after home position is checked. Turned off during stop.)
4. TASK .....Illuminates while any of the robot task, or PLC task, or peripheral task is being executed.
5. POWER .....Illuminates in green while power is on. Illuminates in red when a battery runs out.

Rear View

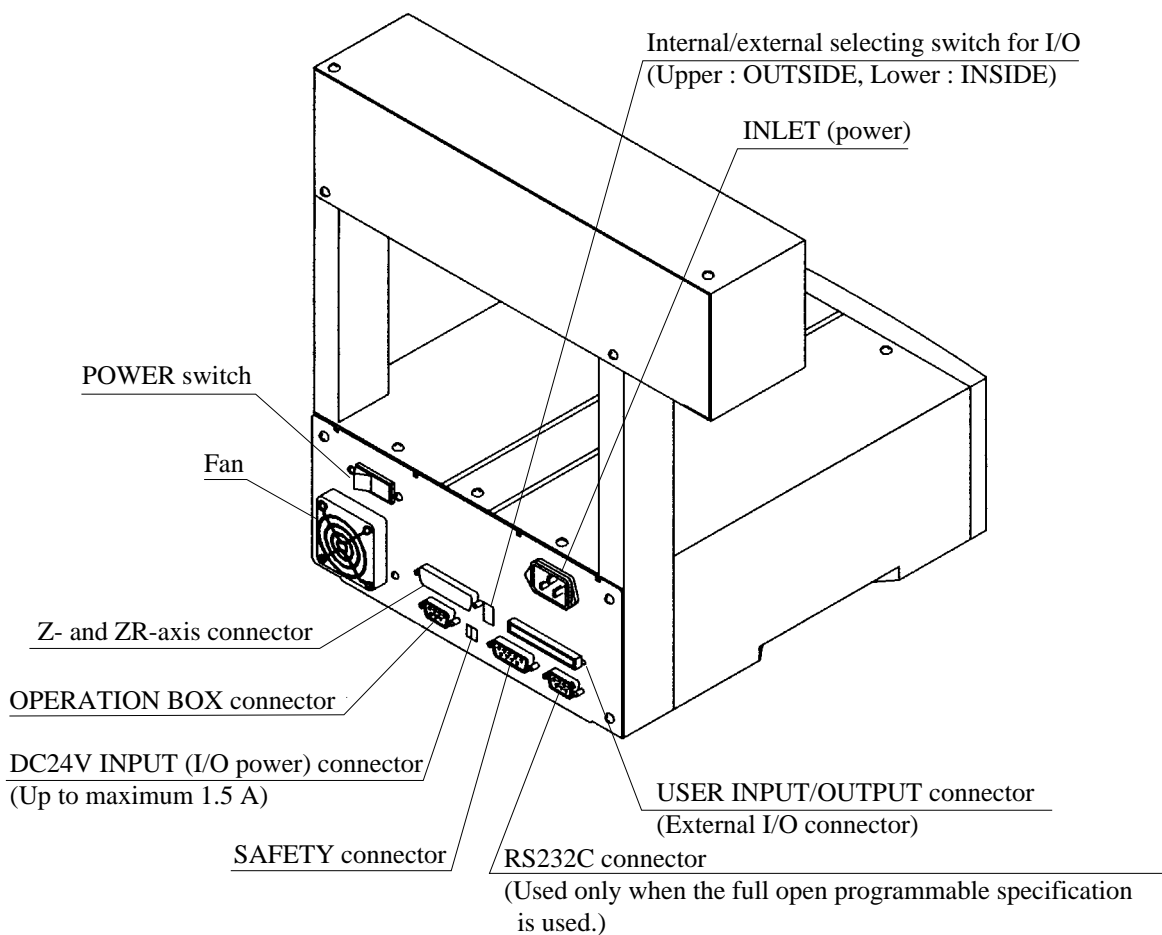

CAST-PRO Teaching Pendant

SRX Teaching pendant

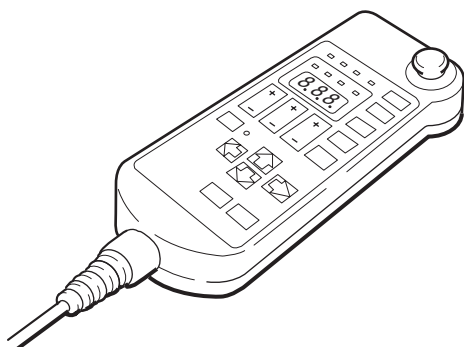

CAST-P06 (option)

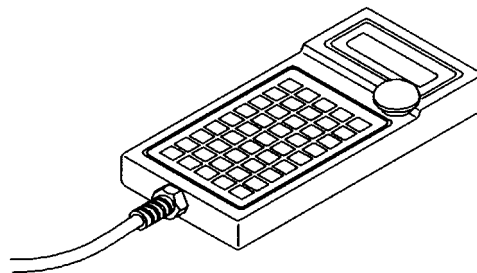

SRX-P005/S (option)



## 1-2 Outline Drawings

### ROBOKIDS Standard Type (CAST-AU4/B2521E)

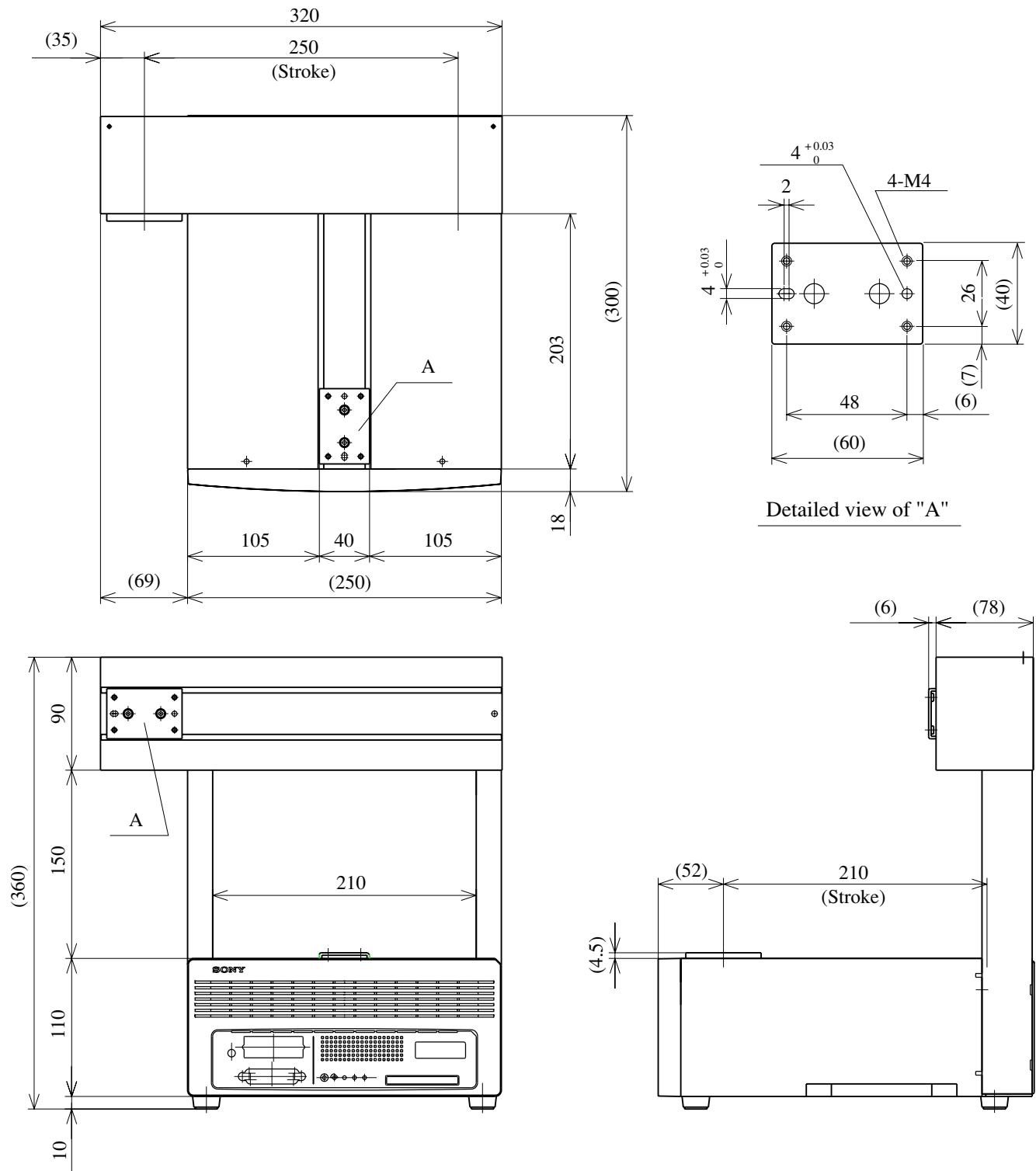

Height Adjustable Type (CAST-AU4/BT2521E)

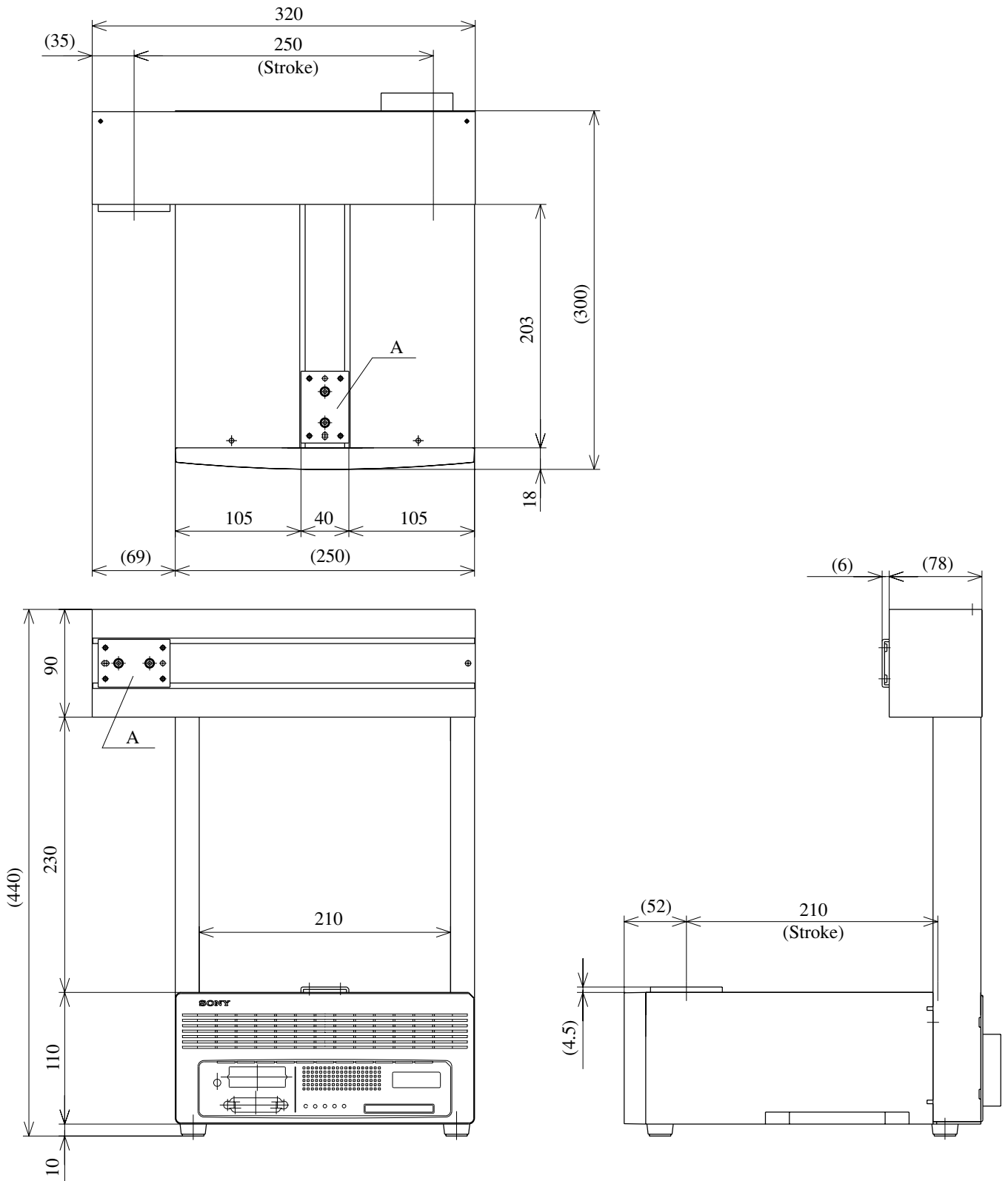

■ 3-Axes Model  
Z-unit

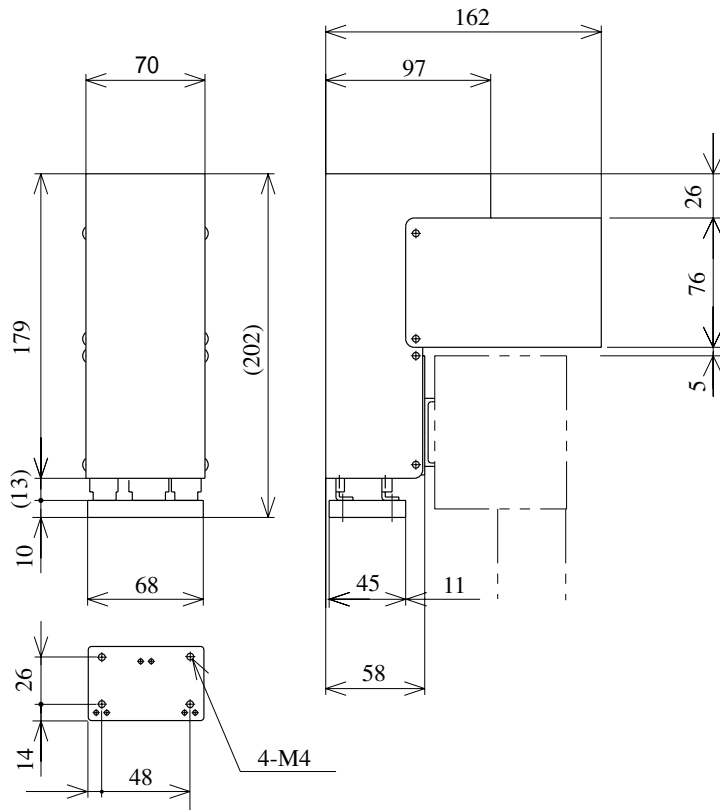

■ 4-Axes Model  
ZR-unit

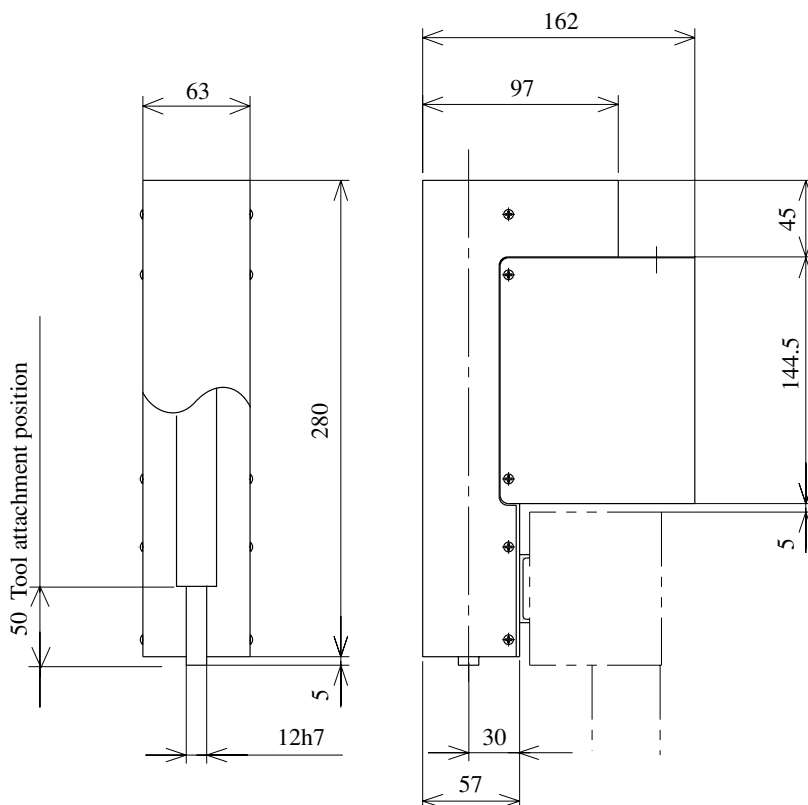

**Service Tapped-Hole Position**

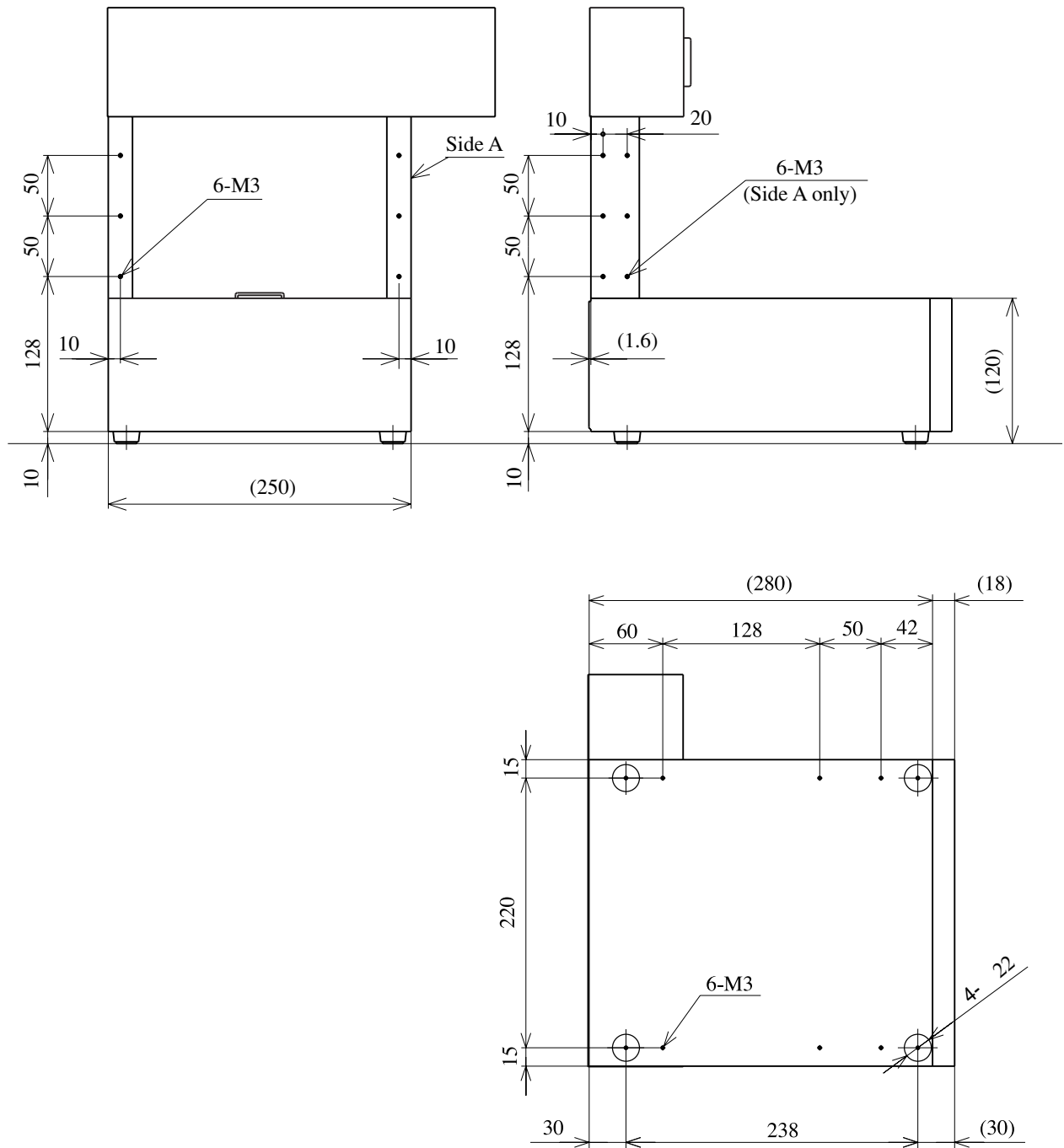

### Service Tapped-Hole Position (Tall Model)

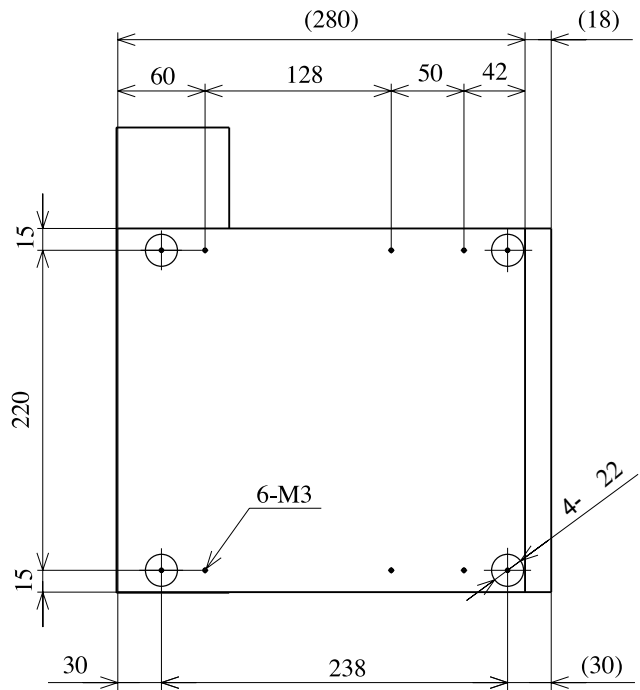
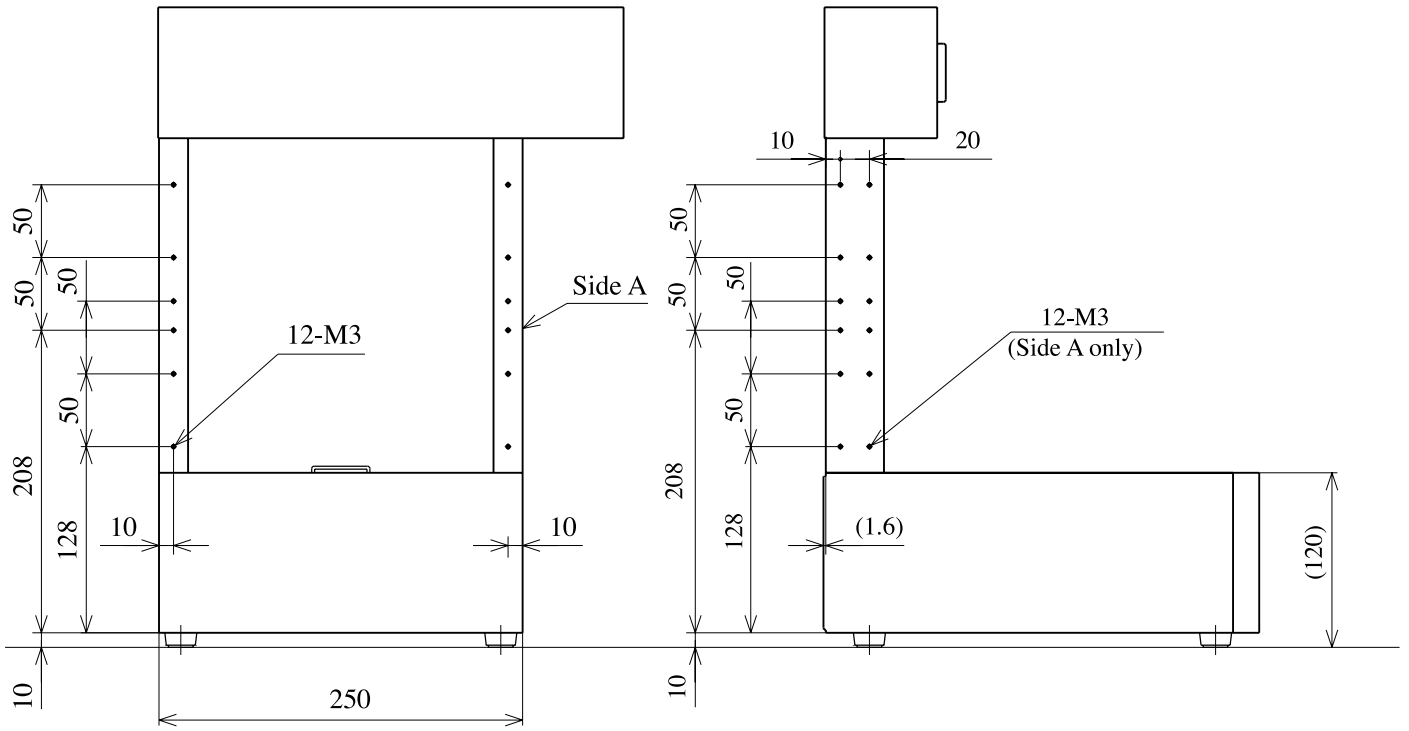

## 1-3 Specifications

### 1-3-1 Machine Specifications

Item		Two axes specification	Three axes specification with Z-axis	Four axes specification with ZR-axis
Work envelope	X-axis	250 mm	250 mm	250 mm
	Y-axis	210 mm	210 mm	210 mm
	Z-axis	–	70 mm	70 mm
	R-axis	–	–	0° to 360°
Maximum speeds	X-axis	300 mm/s (*1)	300 mm/s (*2)	300 mm/s (*3)
	Y-axis(*4)	300 mm/s	300 mm/s	300 mm/s
	Z-axis	–	100 mm/s (*2)	70 mm/s (*3)
	R-axis	–	–	550°/s (*3)
Pose-repeatability (positioning accuracy)	X-axis	±0.05 mm	±0.05 mm	±0.05 mm
	Y-axis	± 0.05 mm	± 0.05 mm	± 0.05 mm
	Z-axis	–	±0.05 mm	±0.05 mm
	R-axis	–	–	±0.1°
Maximum payload	X-axis	5kg	–	–
	Y-axis	5kg	5kg	5kg
	Z-axis	–	2kg	–
	R-axis	–	–	1.8 kg
Resolution (*5)	X-axis	0.014 mm	0.014 mm	0.014 mm
	Y-axis	0.014 mm	0.014 mm	0.014 mm
	Z-axis	–	0.006 mm	0.003 mm
	R-axis	–	–	0.04°
Robot mass (including units)		About 13 kg	About 15 kg	About 16 kg
Operating ambient temperature		0 to 40 °C		

- \*1) The maximum value is subject to the payload of 4.5 kg or less. Set the speed value lower than the maximum value when the payload exceeds 4.5 kg.
- \*2) The maximum value is subject to the payload of 1.5 kg or less. Set the speed value lower than the maximum value when the payload exceeds 1.5 kg.
- \*3) The maximum value is subject to the payload of 1.5 kg or less. Set the speed value lower than the maximum value when the payload exceeds 1.5 kg.
- \*4) The maximum value is subject to the payload of 3.0 kg or less. Set the speed value lower than the maximum value when the payload exceeds 3.0 kg.
- \*5) The resolution does not indicate the absolute position accuracy. It indicates the amount of movement (round-off function) per every pulse that is theoretically calculated from the machine structure. This value changes especially when direction of movement or speed is changed. The resolution value can change depending on the card when the RK card is used.

### 1-3-2 Control Specifications

Drive method	Pulse motor drive (open loop control)
Movement method	PTP, CP
Control axis count	Up to four axes (all axes simultaneous control)
Interpolation function	3-dimensional linear interpolation and 3-dimensional circular interpolation
CP control speed	1 to 100 mm/s
Teaching method	Direct teaching via teaching pendant (option)
	Point program
	Direct data input
Program capacity	Full open : Total 176 Kbytes RK card : Maximum 20 work programs for one operation program. (*)
Point data storage capacity	Full open : 3072 points for one program RK card : 2500 points
Programming method	Full open : Described by the machine language LUNA RK card : The standard software is supplied (option)
General-purpose I/O	22 inputs and 22 outputs
Serial I/F	RS232C : One channel (general-purpose)
Power supply voltage	Single-phase 100 to 240 V $\pm 10\%$ 50/60 Hz
Power consumption	300 VA
Ground	Class 3 ground

\* The 20 work programs of the program capacity item means that the 20 kinds of programs having different point number and different position can be stored.

Refer to the Operation Manual of the memory card (RK card) for the work program assignment.

## 2. Preparation

### 2-1 Attaching the Units

#### 2-1-1 Attaching the Z-unit

##### 1. Fix the supplied mounting plate to the work table. (Two positions)

Hexagon socket head cap screws  
M4 × 10, 2 pieces  
Tightening torque 15 kgfcm

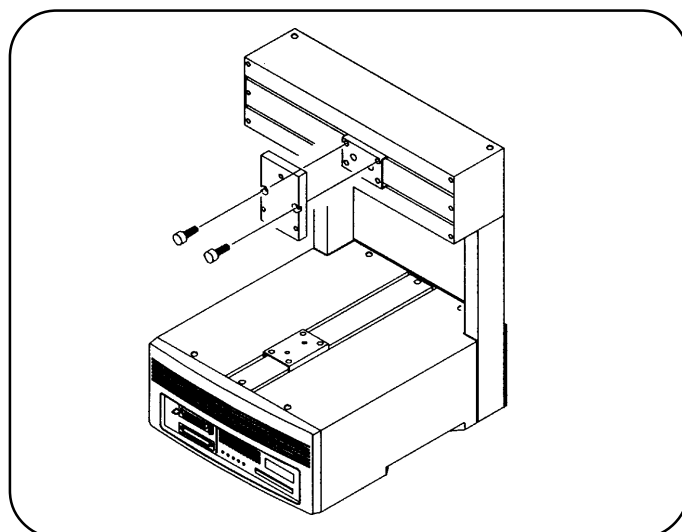

##### 2. Remove the Z-unit front cover. (The cover to which Sony logo mark is attached.) (Four positions)

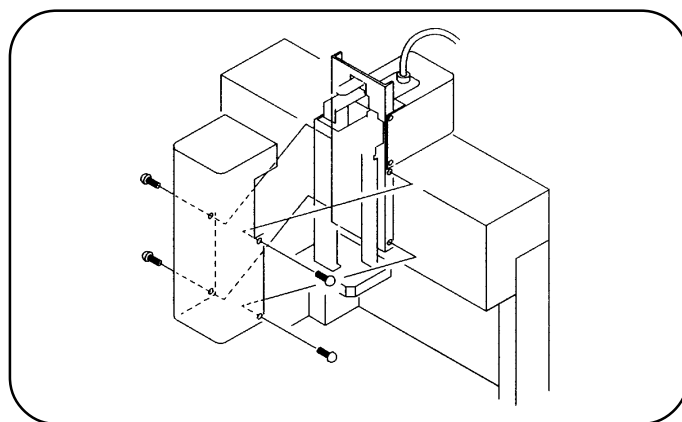

##### 3. Fix the Z-unit to the mounting plate. (Three positions)

Determine the fixing position using the positioning pin that is supplied with the equipment.

Hexagon socket head cap screw  
M4 × 10, 1 piece  
Hexagon socket head cap screws  
M4 × 18, 2 pieces  
Spring washer SW4, 3 pieces  
Flat washer W4, 3 pieces  
Tightening torque 15 kgfcm

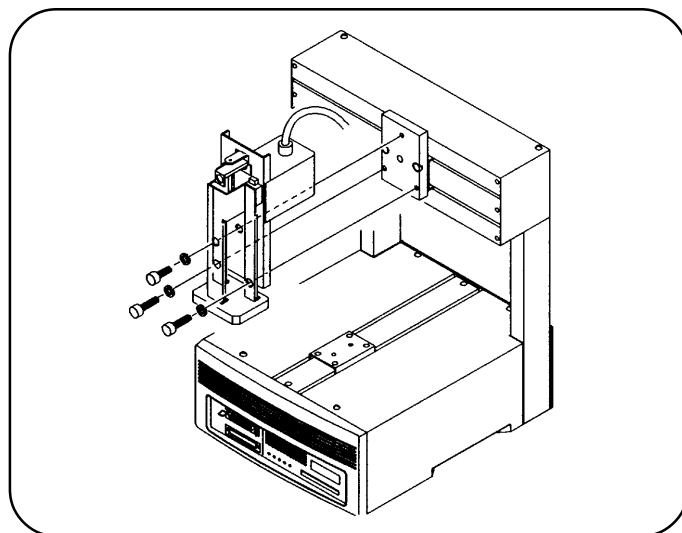



**4. Attach the removed front cover. (Four positions)**

Tightening torque      8 kgfcm

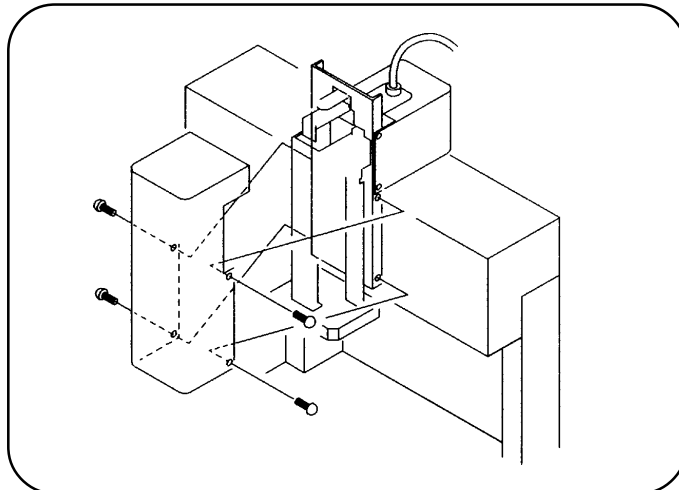

**5. Connect the connectors to the Z-/ZR-unit connectors.**

Be sure to fix the connector by tightening the screws.

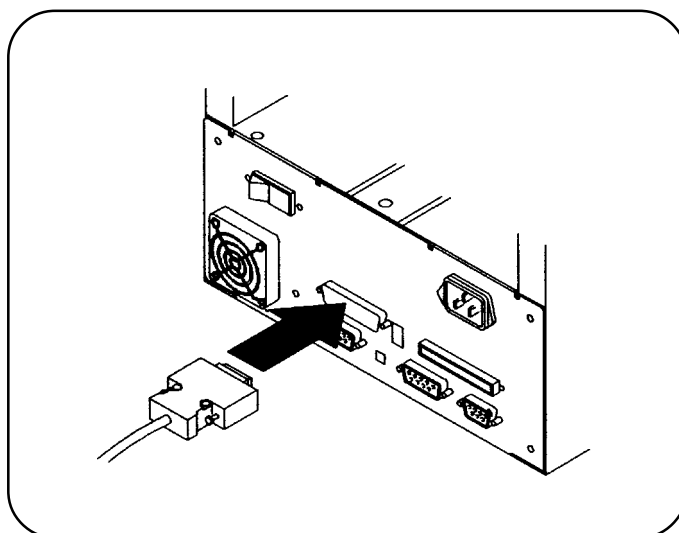

**6. Attach the cable holder supplied, to the post.**

Hexagon socket head cap screws      M3 × 6, 2 pieces  
Spring washer      SW3, 2 pieces  
Flat washer      W3, 2 pieces  
Tightening torque      10 kgfcm

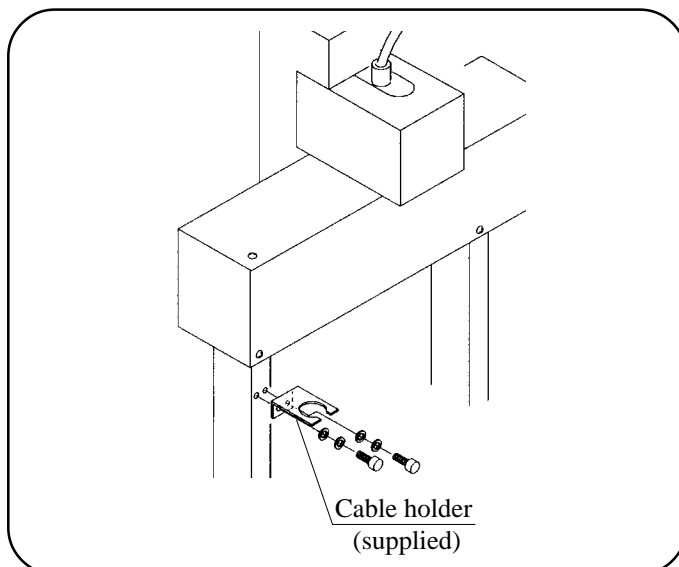

7. Fix the cable clamp of the cable to the cable holder.

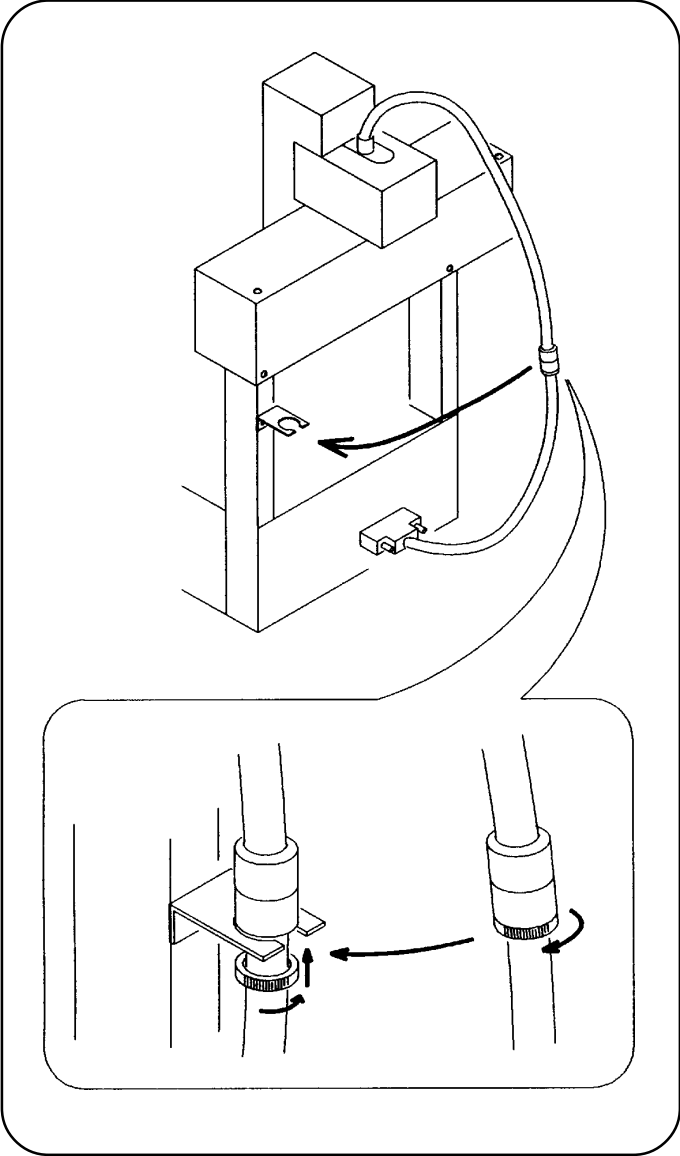

## 2-1-2 Attaching the ZR-unit

1. Remove the front cover. (The cover to which Sony logo mark is attached.) (Six positions)

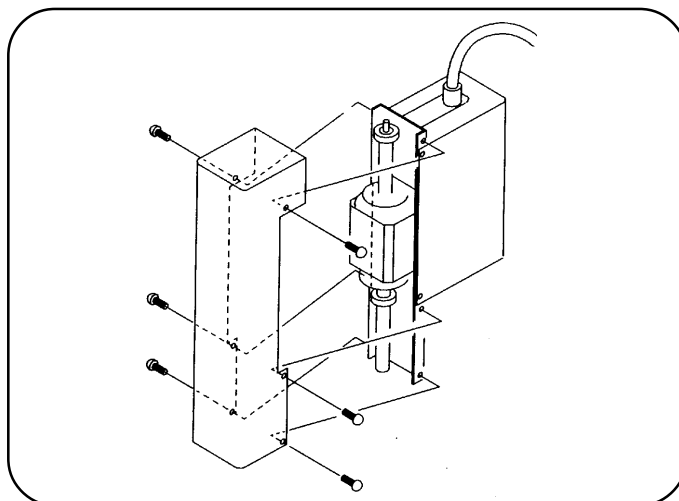

2. Fix the ZR-unit to the mounting plate. (Four positions)

Determine the fixing position using the positioning pin that is supplied with the equipment.

Hexagon socket head cap screw	M4 × 6, 4 pieces
Spring washer	SW4, 4 pieces
Flat washer	W4, 4 pieces
Tightening torque	15 kgfcm

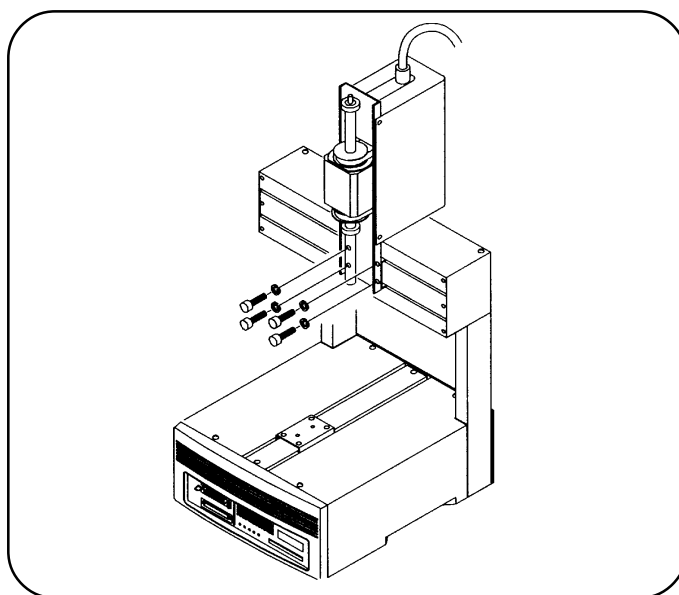

3. Attach the front cover. (Six positions)

Tightening torque	8 kgfcm
-------------------	---------

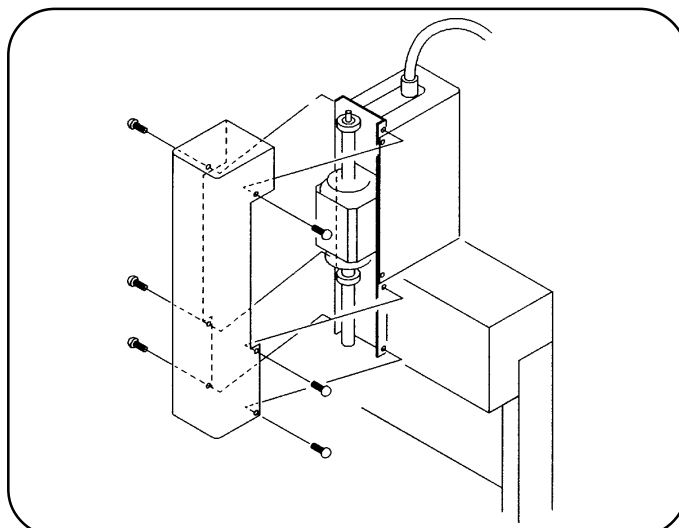

#### 4. Connect the connectors to the Z-/ZR-unit connectors.

Be sure to fix the connector by tightening the screws.

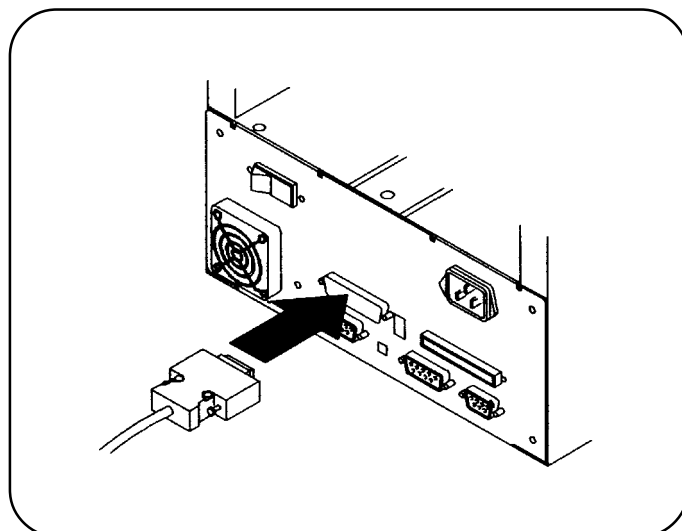

#### 5. Attach the cable holder supplied, to the post.

Hexagon socket head cap screws

M3 × 6, 2 pieces

Spring washer

SW3, 2 pieces

Flat washer

W3, 2 pieces

Tightening torque

10 kgfcm

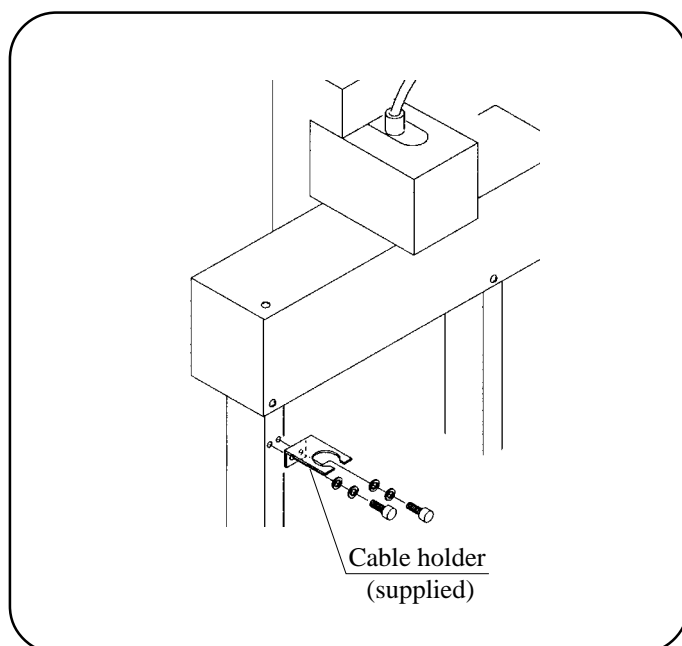

5. Fix the clamp of the cable on the cable holder.

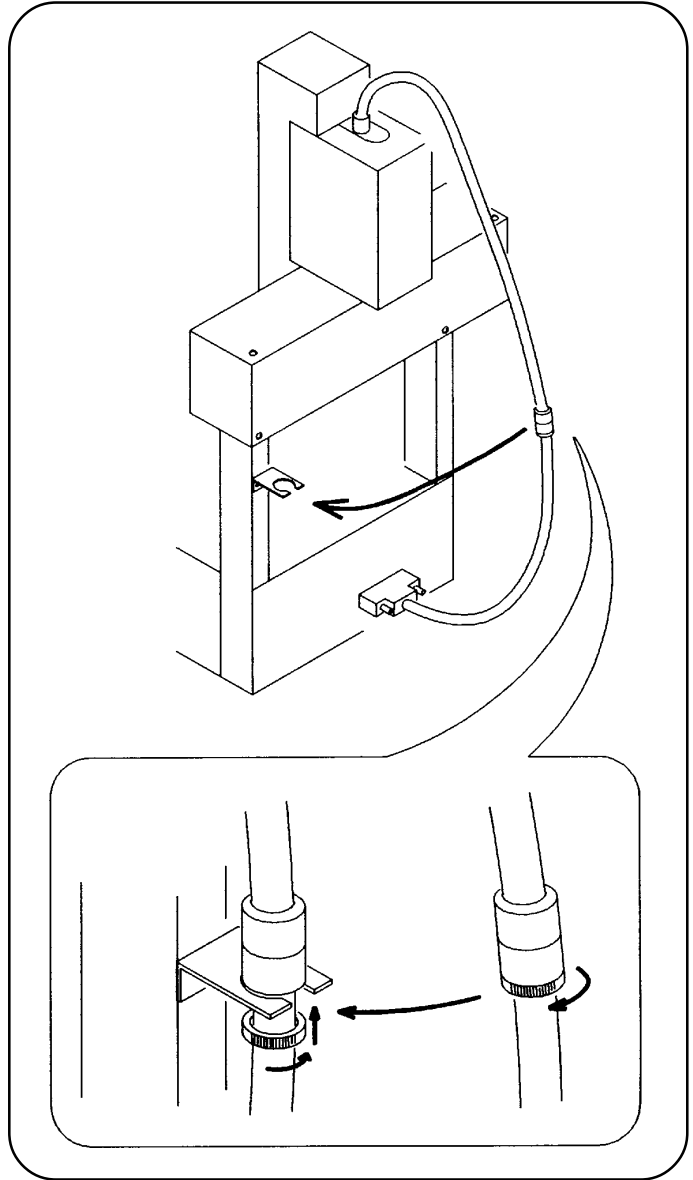

## 2-2 Connecting the External Signal

The base machine is equipped with the following connectors for external signal communication.

- SAFETY (for external switch) connector (rear)
- External Stop (same function as the STOP button of the main unit)
- Door, barrier
- External return (same operation as the RETURN button in the two operators line mode operation)
- USER INPUT/OUTPUT (EXTERNAL I/O) connector (rear)
  - Selecting programs (same operation as the PROGRAM switch of the main unit) : (I3 ~ I10)
  - Error reset (There is no switch corresponding to this function.) : (I11)
  - External start (same operation as the START button of the main unit) : (I1)

### 1. Connect an external switch to the SAFETY connector by soldering.

Connect the wires to the corresponding pins of the external switch connector.

Refer to the connector diagram for external switch, for the signals at the respective pins and type of mating connector.

How to control the stop:

- Connect pin-10 and pin-11 to the respective switches.
- Connect pin-14 to pin-15. (or to pin-7)

How to control the RETURN :

- Connect pin-9 and pin-7 (or pin-15) to the respective switches.

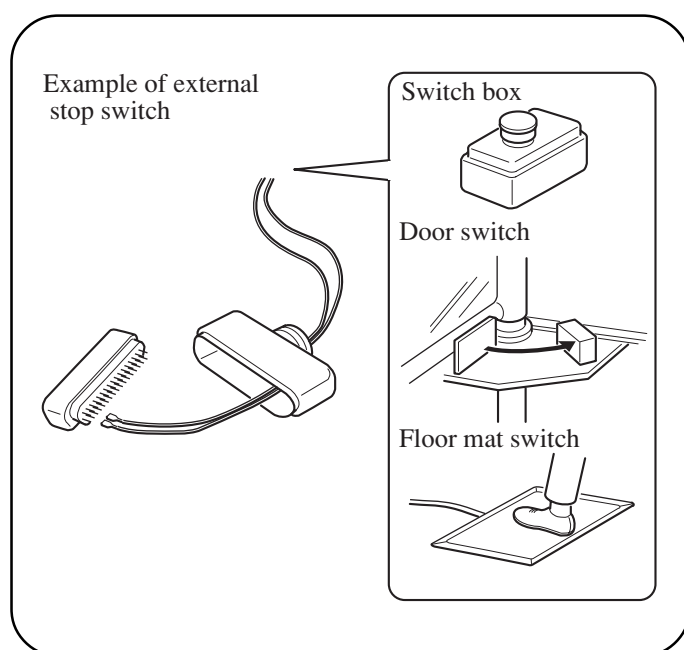

Connector for external switch (SAFETY)

Safety box

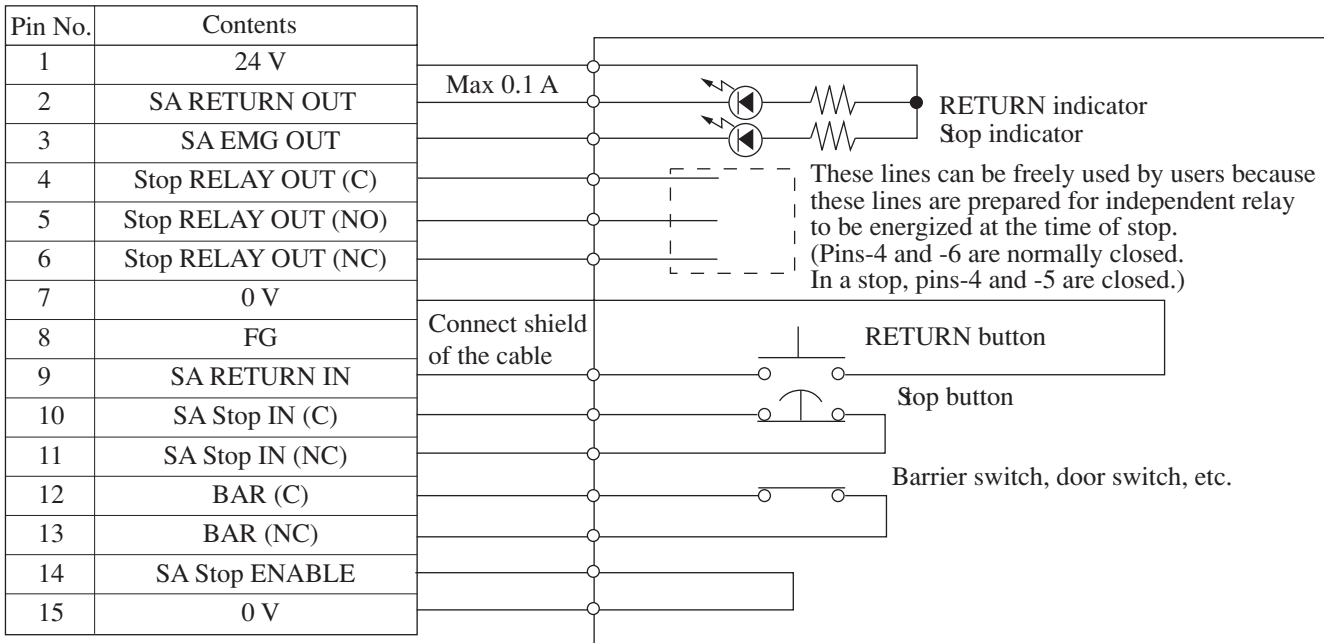

### Wiring diagram of connector for external switch (SAFETY)

Applicable plug Type : DA-15PF-N (pin connector)

Applicable shell Type : DA-C4-J10

#### NOTE

- ◆ An external stop button can be inserted between pins-14 and -15, or between pins-14 and -7.
- ◆ Be sure to use a shielded cable. The maximum length of a shielded cable is 1.5 m. The external shield must be connected to pin No. 8.
- ◆ The external equipment (switch, indicator, box, etc.) to be used for external operation must be prepared by users.

## 2. Connect the external signals to the USER I/O connector by soldering.

Connect the wires to the corresponding pins of the USER I/O connector.

For the signal names and pin numbers of the respective pins, refer to the I/O connector input/output specifications, Operation Manual (or Operation Manual of Full Open Programmable in the case of the full open programmable specifications) of memory card (RK card).

### *Precautions on operating the ROBOKIDS*

*When using the RK card, connect the I/O connector supplied to the USER I/O connector S11 (SYSRUN) of the machine as shown.*

#### • USER I/O connector (supplied)



Pin No.	Name
1	0 V
3	SYSRUN

Connection

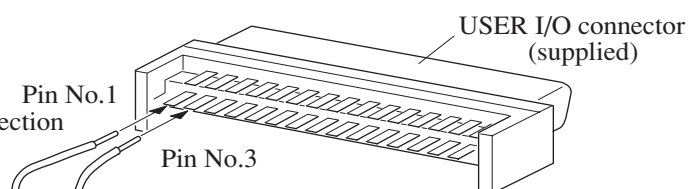

#### • Pin arrangement

2	4	6	8	~	30	32	34	
1	3	5	7	9	~	29	31	33
	36	38	40	42	~	64	66	68
35	37	39	41	~	63	65	67	

\* Connect a jumper wire to the USER I/O connector (supplied), with soldering, attach the connector supplied (accessory) to the connector.

## 3. Controlling the program selector from external location. (RK card only)

Connect the wires to the pins of the USER I/O connector corresponding to the external signals, by soldering. (I3 to I10)

Set the first digit of the PROGRAM switch to “F” when controlling the program selector from external location.

If the second digit of the PROGRAM switch is set to “F”, the application program is set to external mode.

PROGRAM switch

Controlling the program selector from external location ••• Set to “F”

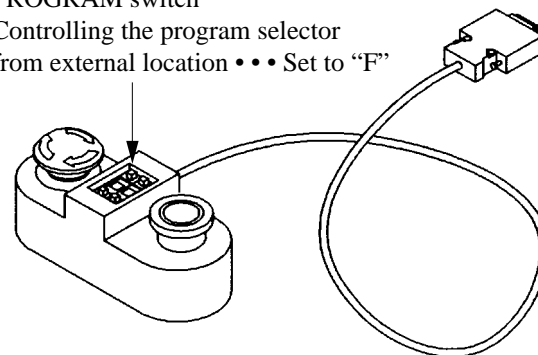



## Input Circuit

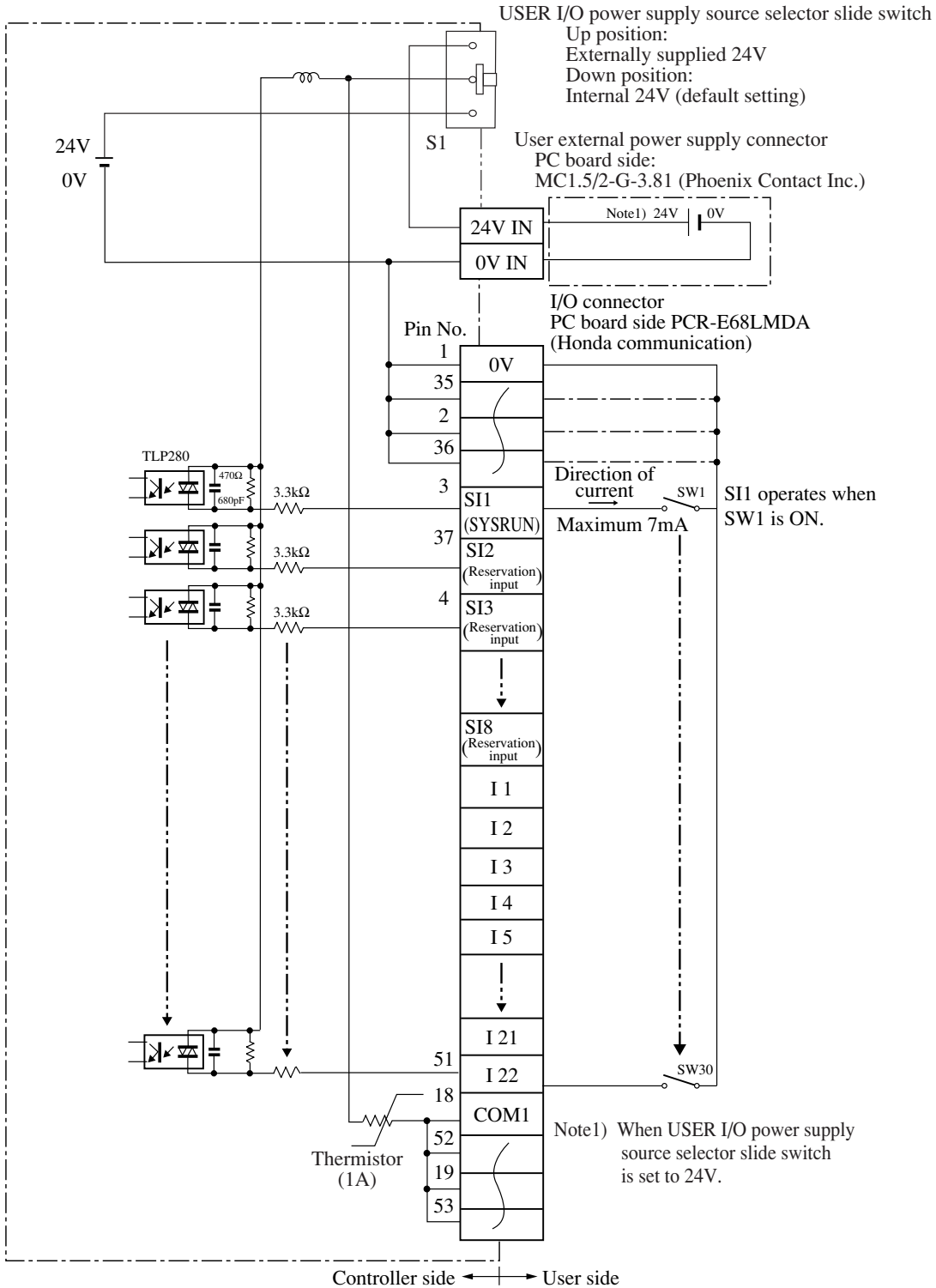

## Output Circuit

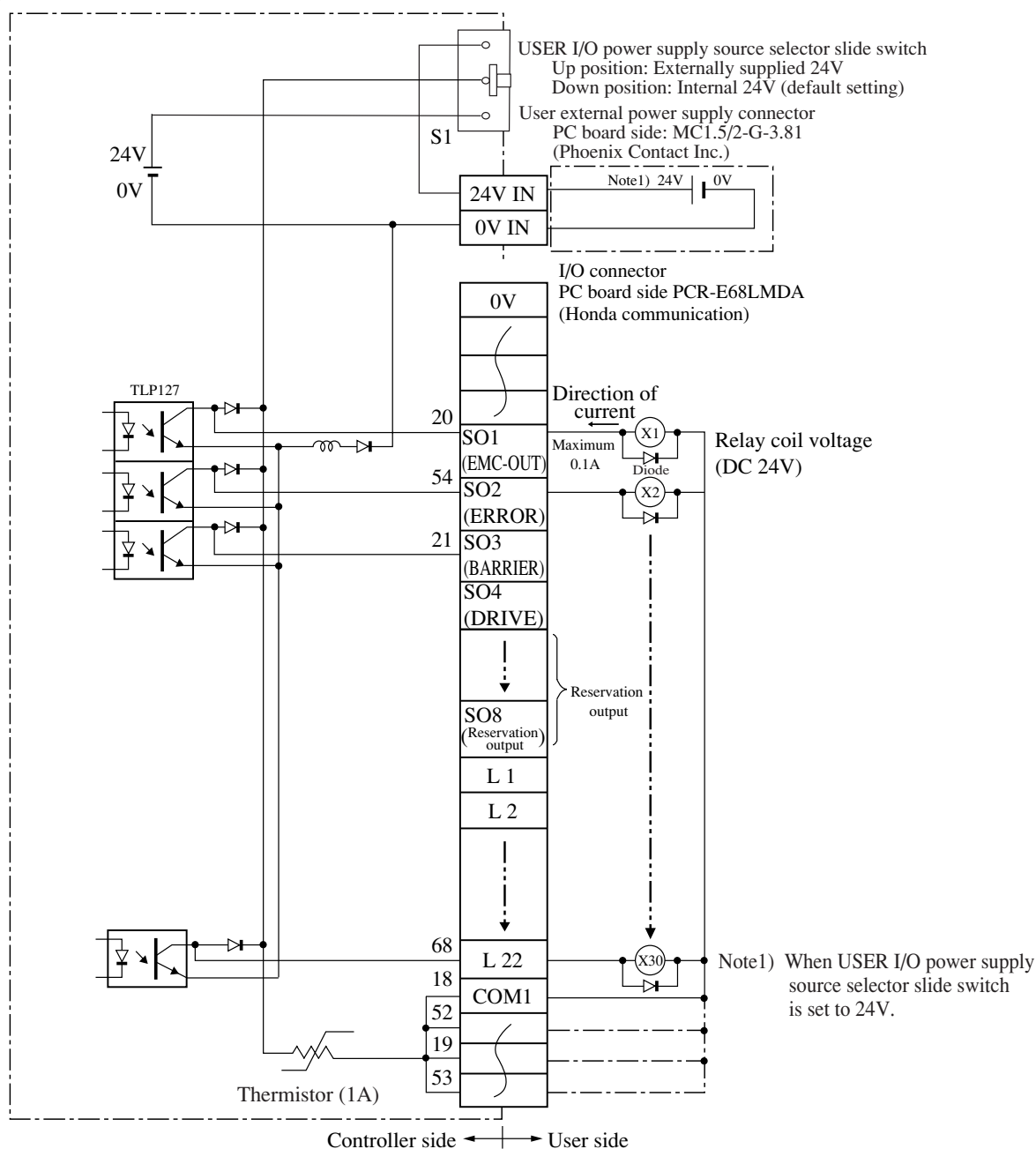

### NOTE

- ◆ Add the diodes as shown when relay coils are connected as the load.
- ◆ Be careful that the thermistor operates to shut down the +24 V power supply when 24 V output is used and the current of 1 A or more flows. Modify the external circuit to reduce the current capacity to 1 A or less. Thermistor shuts down the +24 V power supply and returns when the main power is turned on again.  
(The maximum current capacity of internal power supply is 1 A.)
- ◆ Be careful that current capacity is maximum 0.1 A per one output point.
- ◆ Be sure to use a shielded cable for I/O connection. The maximum length of a shielded cable is 1.0 m. Use the core conductor of the shielded cable.

## 2-3 Connecting to an Electrical Outlet

Prepare the power cable for AC 200 V to 240 V referring to the following connection diagram. The user must provide and wire an AC power plug to connect to the AC outlet.

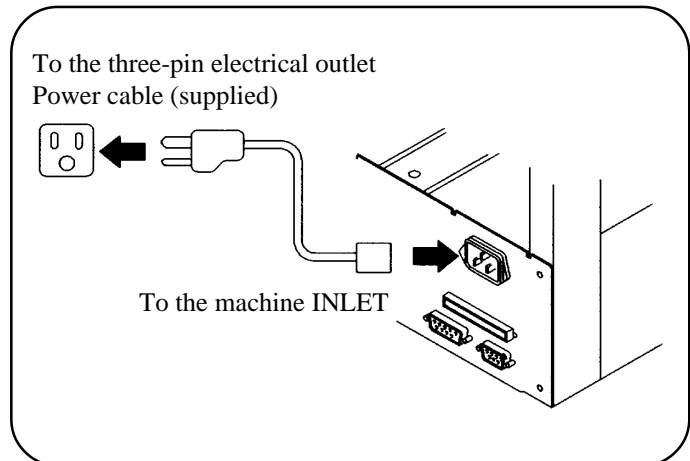

Connection diagram of the AC power cable for 200 V to 240 V

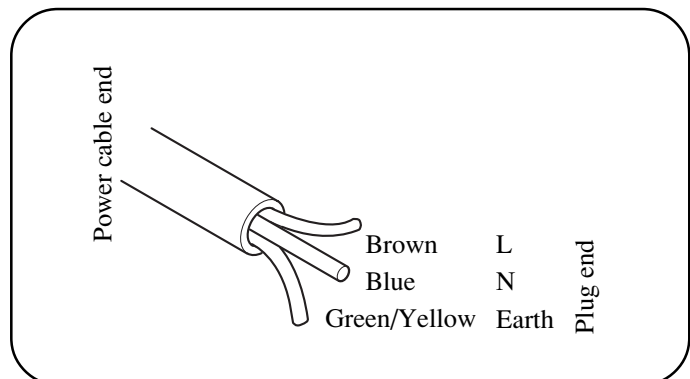

## 2-4 Starting Up the Base Machine

Make sure that the main power is turned off.  
Connect the operation box.

### 2-4-1 Full-open Programmable Specification

Turn on the power switch on the rear panel. Subsequent operating procedure changes depending on the application created by user.

### 2-4-2 When Using Memory Card “RK card”

Before operation ensure that an application memory card (RK card) is inserted in the memory card slot. When you have purchased another type of optional memory card in order to use the robot in another assembly type, re-insert the new card to the memory card slot.

**1. Make sure that the main power is turned off. Insert the memory card into the memory card slot.**

Do not remove or insert a memory card while power is turned on. It may cause trouble.

**2. Connect the USER I/O connector (in which SYSRUN is shorted) to the rear panel of the ROBOKIDS. (Refer to page 2-6.)**

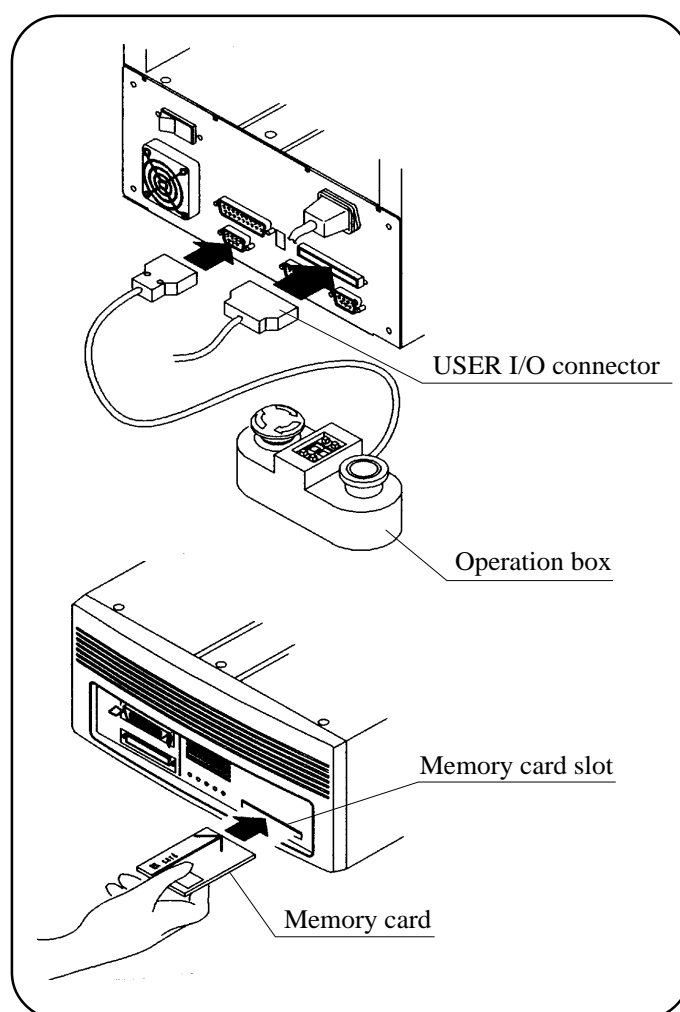

**3. Turn the base machine on.**

About five seconds later, the white indicator of START button starts flashing in green.

**4. Press the START button.**

The machine starts returning home.

The green indicator of the START button turns on and changes to slow flashing after completing home return. (About 30 seconds later)

**5. Press the START button again.**

The green indicator of START button turns on and the machine starts assembling work.

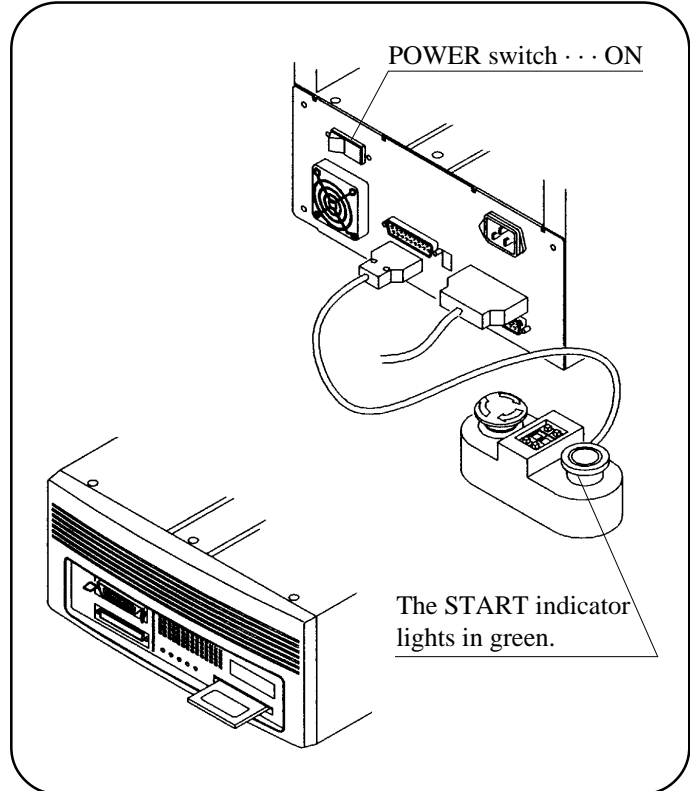

**NOTE**

*Do not remove or insert a memory card while the power is turned on.*

*The machine will not work if the memory card is removed.*

*Before turning on the machine, always insert the memory card in the memory card slot first. The main assembly control program (the teaching pendant software only in the semi-programmable specification) will then be loaded automatically into the unit whenever the machine is turned on.*

*This operation does not load the point programs: such design prevents the internal point programs (created as a result of a teaching) from being overwritten by mistake.*

## 3. Maintenance

### 3-1 Maintaining the Machine

Clean the surfaces of the machine with a soft dry cloth. If the stain is difficult to remove, use cloth moistened with a mild detergent solution, followed by using a dry cloth. Do not use volatile solvents such as alcohol, benzene or thinner, as they may mar the finish.

Consult your local Sony dealer for the consumable parts, jigs and tools which are required for maintenance.

### 3-2 Greasing the Machine and Removing the Fallen Materials

When shipped, the machine is greased along the guide rails of the X- and Y-axes. This ensures smooth operation of the work table. To maintain the machine in top condition, grease the rails and remove the fallen materials every 6 months. Use the NSK grease No. 1 (Nippon Seiko or Multemp LRL3 equivalent).

1. Turn off the power of machine, and unplug the power cord from an electrical outlet.

When the Z unit is used, move down the Z-axis to the bottom and turn off the POWER switch.

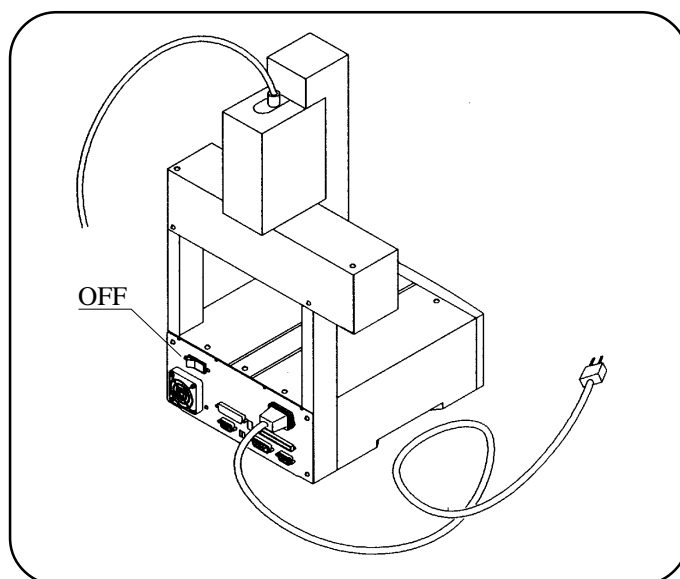

2. Remove the screws securing the X-axis and Y-axis cover, and also the front cover of Z unit and ZR unit (also Z-axis cover for the 3 axes specification).

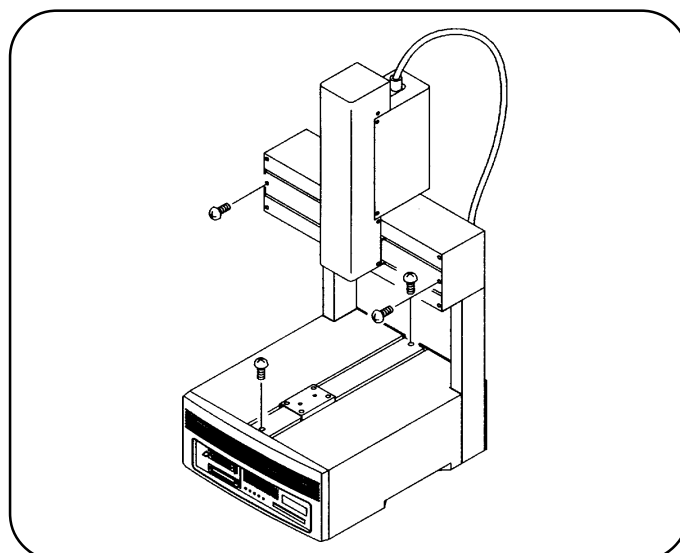

3. **Move the work table and the work unit to the ends by hand, remove the X-axis and Y-axis covers by pulling them, then remove the fallen materials such as screws.**

Remove the front cover of the Z-unit and ZR-unit also.

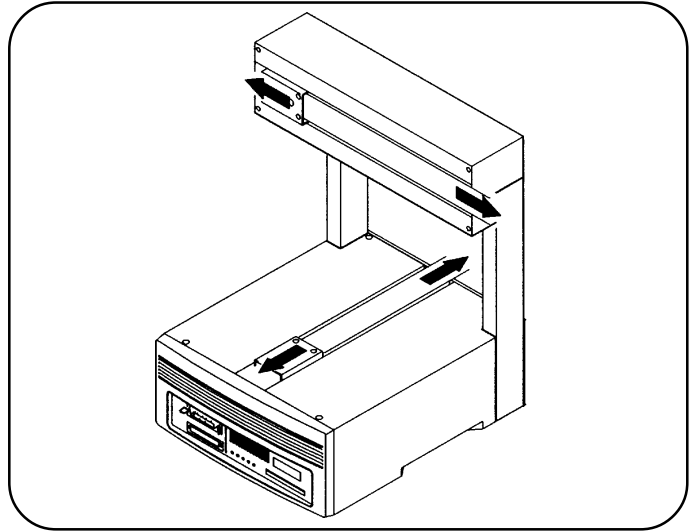

**NOTE**

*If the work table and the work unit are not moved to the ends as indicated, they may cause damage to the covers.*

4. **Wipe of the old grease and apply grease at the center of each side of the X-axis and Y-axis guide rails.**

Apply about 0.2 g of grease.

Be careful not to apply grease to the drive belts.

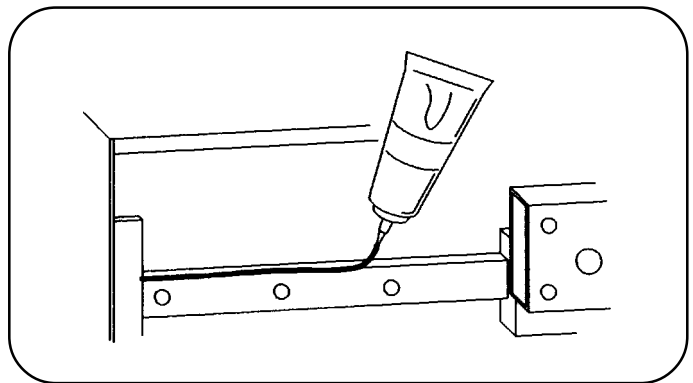

5. **Move the work table and the work unit to the left and to the right several times to spread the grease over the length of each rail.**

Wipe off extra grease at the ends of each rail with a cloth. (Extra grease will be solidified causing malfunction.)

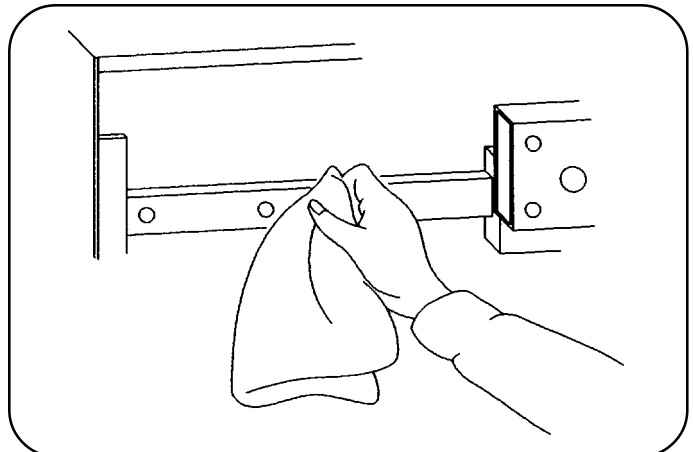

6. Apply grease to the Z unit and the ZR unit as shown in the same manner.

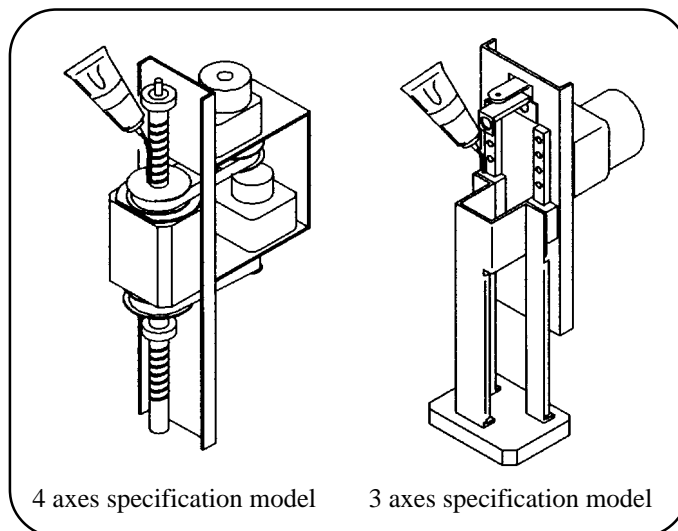

7. Attach the covers of the X-axis, Y-axis, Z unit and ZR unit to their original positions.

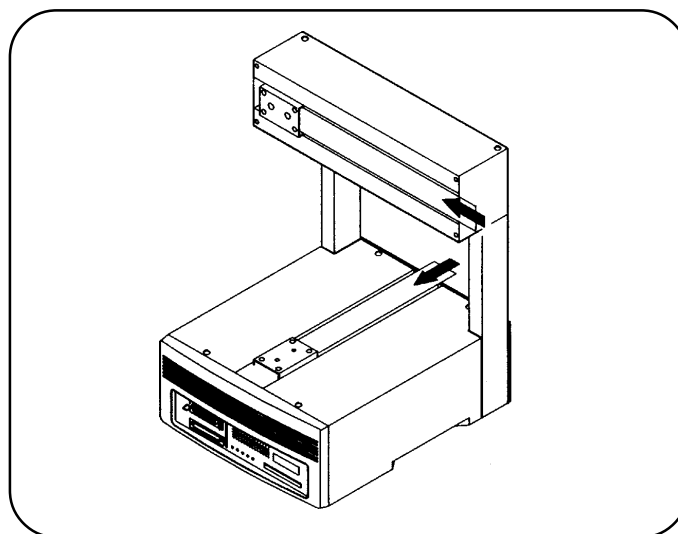

**NOTE**

- ◆ Be careful not to damage the covers when they are reinstalled.
- ◆ After the covers are attached, move the respective axes using the teaching pendant until grease covers all necessary part.
- ◆ Be careful that the motors get very hot immediately after the operation is stopped.



### 3-3 Cleaning and Replacing the Air Filter

Air is circulated in the controller of the base machine to cool the controller. The cooling air is introduced through the air filter on the rear of the machine. Dust may be accumulated choking the air filter which decreases the cooling power causing serious damage such as thermal breakdown of ICs if the air filter is not properly maintained. Clean the air filter once every six months. If the air filter is heavily clogged, replace the air filter.

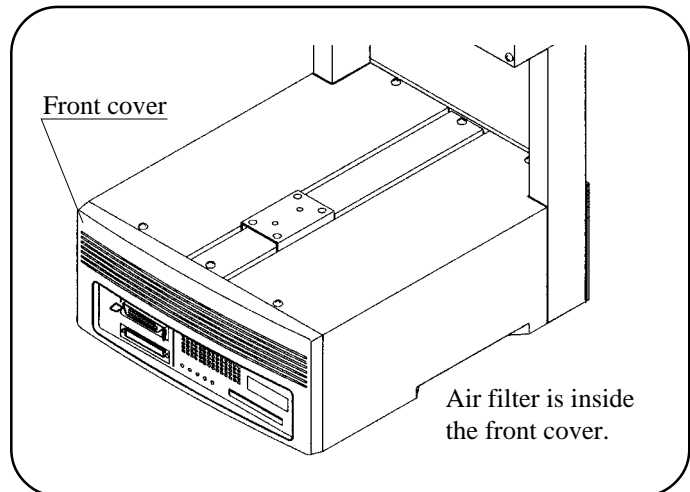

1. Turn off the POWER switch and unplug the power cord from an electrical outlet.
2. Remove the front cover.

Remove the bottom screws. While pulling the bottom of the cover to the front, raise the catches on the top.

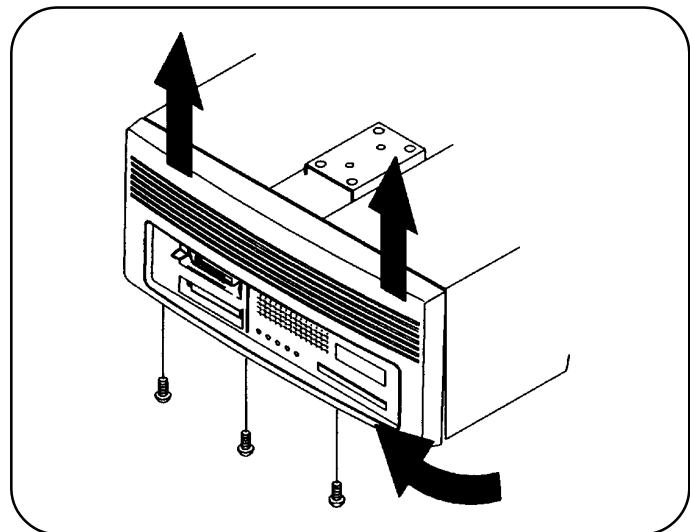

**3. Replace the media (filter).**

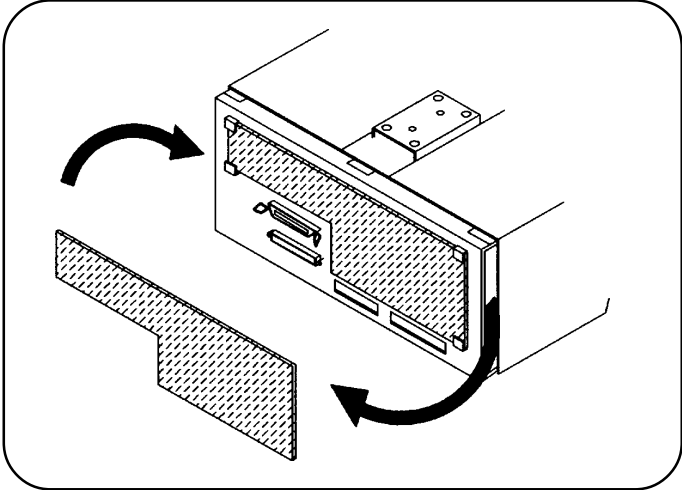

**4. Reinstall the front cover as before.**

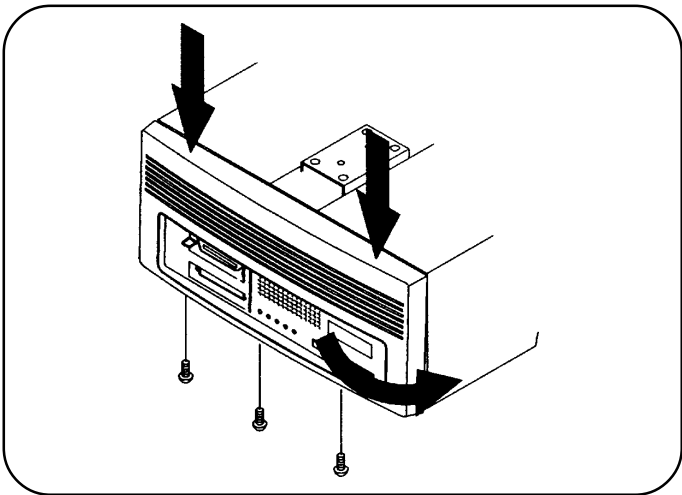

— Replacement media —  
Sony Order No. .... 4-761-607-01

### 3-4 Replacing the Battery

1. Turn off the **POWER** switch and unplug the **AC power cord** from the **AC outlet**.

The battery is located in the recess at the bottom on the rear of the Z-axis.

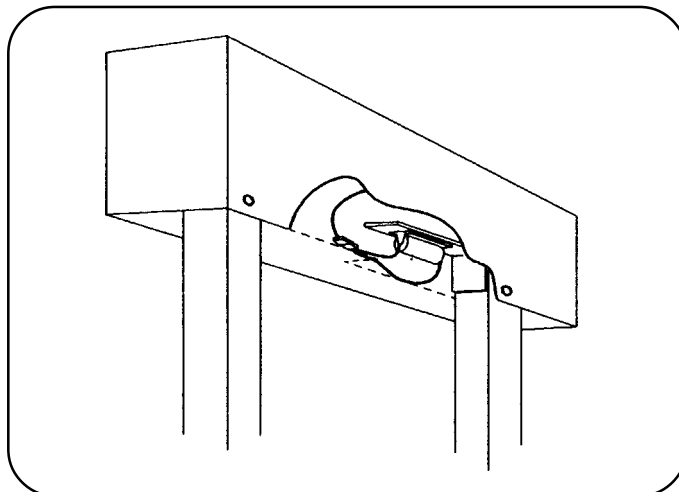

2. Exchange the battery with the new lithium battery.

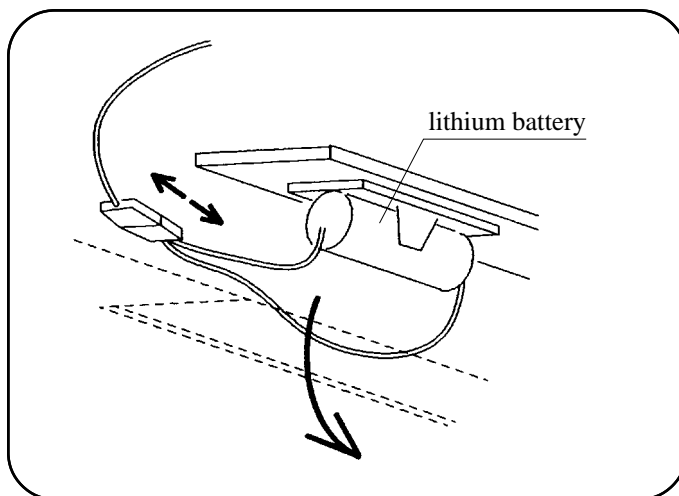

**NOTE**

*Battery replacement must be completed within eight hours after the main power is turned off. If not, internal data can be damaged.*

Replacement lithium battery (primary battery)

Sony Order No. .... 1-528-932-11

## 4. Troubleshooting

### 4-1 Common Items

#### 4-1-1 Stepping Out (Note 1)

The machine performs open loop servo control using a pulse motor (stepping motor) without positional feedback. The machine thus continues to operate with positional error even if it steps out due to overloading of the retaining torque of the motor.

When the base machine steps out, or when it operates with positional errors, check the following items first.

##### (1) Overloaded

The base machine has a limited carrying loading. Check whether the load exceeds the maximum payload that the respective axes can carry by referring to page 1-6, section 1-3, "Specifications."

The payload with which the machine can operate at 100% speed is smaller than the maximum payload, and varies for each axis. Check the actual load weight before operating the machine.

##### (2) External force

External forces from cables and pipes are normally larger than anticipated, and can easily exceed the retaining torque of the motor. Be careful of unexpected external forces when using stiff wires or pipes that cannot be easily bent.

##### (3) Rapid speed change

When a rapid speed change occurs such as an immediate returning movement while an interpolation operation is being performed, the load inertia may exceed the retaining torque of the motor, causing the motor to step out.

Before performing such a movement, reduce the operating speed.

Example : Returning movement of the circular interpolation operation

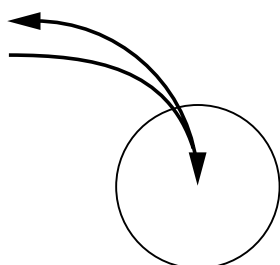

Example : Returning movement of the Z-axis operation

(Movements are synthesized sometimes.)

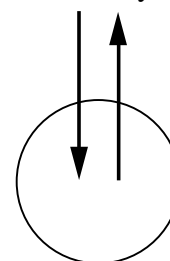

Note 1 : What is "stepping out"?

When the drive shaft of a motor is overloaded beyond the torque of the motor, the drive shaft spins (revolves swiftly without control) regardless of the control that is applied to the motor.

This is called "stepping out".

This term is sometimes used incorrectly for tooth-skipping (between pulley and belt), but stepping out and tooth-skipping are actually entirely different phenomena.

(4) Synthesis of movements in the same direction

In some programs, the machine is operated by synthesizing two movements (the FOS and PFOS with the AWAKE instruction of LUNA).

When the teaching points to be synthesized are aligned on the same line, the machine can step out.

When such a movement is experienced, the application program must be modified.

(5) Eccentric loading

When a load (tool, work, etc.) is very eccentric or far from the mounting surface, stepping out can occur even though the load is lower than the maximum payload. If the weight balance cannot be improved, reduce the operating speed.

(6) Mounting screw

When a mounting screw is so long that the tip of the screw touches the cover or other object, it can cause stepping out. You can detect this trouble by listening for a rubbing sound or looking for scars. Check for these before use.

(7) Belt tension

If the belt tension becomes abnormal, contact your Sony dealer from which you purchased the machine, or contact Sony Max Corporation FA Service.

(8) When the machine is operated at low temperature

In early morning during winter, the room temperature may fall to 0°C or lower. The temperature inside the machine takes time to rise even though the temperature of the room can be increased by using a heater.

In this case, run the machine for half an hour at half the specified speed, or wait until the temperature of the machine rises to the temperature of the room.

### 4-1-2 External Noise

External electrical noise is a difficult problem because it is invisible. Take the following remedial measures. If the symptom disappears, electrical noise was probably the cause of the trouble.

(1) Earthing the power supply

Always connect the earth of the AC output to ground (Class 3 ground).

If the earth is not connected, the equipment is susceptible to electrical noise.

(2) Separation of AC connections

Connect the AC power of the machine to a separate AC outlet from any equipment that generates significant electrical noise.

(3) Cable length

The cables connected to the machine can function as antenna and pick up electrical wave noise. Make the cable length as short as possible, and use shielded cables where possible.

The teaching pendant is connected by a long cable to the ROBOKIDS, so disconnect the teaching pendant when not in use.

### 4-1-3 Abnormal Sound from Unit's Motors

The Z unit motor and the ZR unit motor are equipped with brakes; these motors may occasionally produce abnormal sounds such as scratching or crunching noises. These sounds are caused by the structure of the brakes and are not a problem.

Also, a squeaking or creaking sound may be heard when the emergency stop switch is pressed during AUTO operation. These are the stepping out sound that is generated when the Z-axis is forcibly stopped by stepping it out in order to prevent the Z-axis from moving down during an emergency stop. These sounds cause no problem in terms of reliability.

## 4-2 Full-open Programmable Specifications

Connect the SRX teaching pendant via a debug station and check the error codes and error history using the following procedure.

- 1 Connect a debug station.
- 2 Connect the SRX teaching pendant.
- 3 Press the MANAGEMENT key and select “Error History” with the F4 key by scrolling the cursor using the   key.

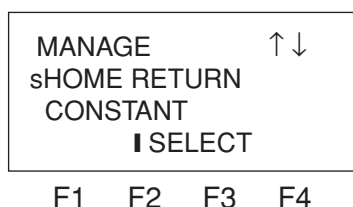

- 4 The error history is displayed.

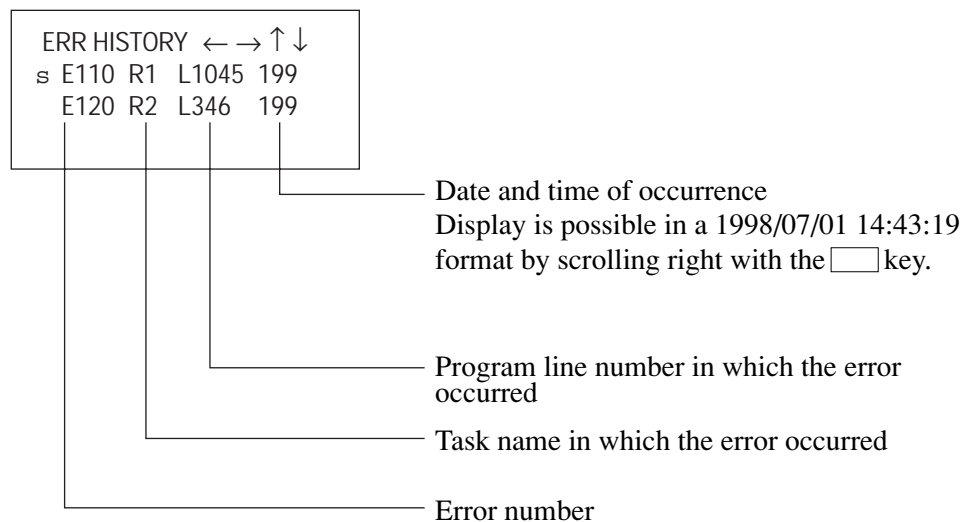

A list of errors is displayed starting from the most recent occurrence.

When an error occurs, it is registered in the top (the topmost line) and the oldest error is deleted.

- 5 Check the error code number E\*\*\* on display and find out causes and countermeasures referring to the following table.

When the machine does not operate normally, check the error contents referring to the following table. For the contents that are unique to the respective applications, refer to the Operation Manual of the memory card (RK card), and take the appropriate measures.

Error No.	Causes	Solutions
E000 ~ E030	CPU board is defective	Replace the Base board
E031	Internal memory overflows	Delete the unnecessary programs
E100	System task not present error (full open)	Install the system task
E110	Object code error	When the Power lamp lights up in red, replace the battery. If it does not corresponds to any of the above contents, contact Sony sales or service office.
E111	System task command error (full open)	Correct the program
E112	Robot command error	Correct the program of system task or peripheral task
E113	I/O number error	Correct the I/O number
E114	Point data not present error	Load the point number. Replace the CPU board
E115	Error of point number specified	Correct the point number
E116	Parameter error	Correct the variables specified
E117	Array number error	Correct the array number
E118	Integer value out of range error	Correct the integer value
E119 ~ E124	Syntax error	Correct syntax
E130	X-axis (tool axis) out of operation range error	Correct the target point to which the tool moves
E131	Y-axis (work axis) out of operation range error	Correct the target point to which the tool moves
E132	Z-axis (tool axis) out of operation range error	Correct the target point to which the tool moves
E133	R-axis (tool axis) out of operation range error	Correct the target point to which the tool moves
E134	X-axis system limit error	Correct the speed so as not to exceed the range
E135	Y-axis system limit error	Correct the speed so as not to exceed the range
E136	Z-axis system limit error	Correct the speed so as not to exceed the range
E137	R-axis system limit error	Correct the speed so as not to exceed the range
E138	X-axis point limit error	Correct the speed so as not to exceed the range
E139	Y-axis point limit error	Correct the speed so as not to exceed the range
E140	Z-axis point limit error	Correct the speed so as not to exceed the range
E141	R-axis point limit error	Correct the speed so as not to exceed the range
E154	Speed is too fast for the distance between the two points during interpolation operation	Increase the distance between the two points, or decrease the speed
E155	The circular auxiliary point (ENTER B) and start point/end point are aligned on a straight line during circular interpolation operation. Circle is taught in 360 degrees	Correct the position of the circular auxiliary point, or divide the movement into smaller segments of less than 360 degrees
E200 ~ E204	PLC program error (full open)	Correct the program
E300	Emergency stop is triggered	Cancel the emergency stop switch



Error No.	Causes	Solutions
E301	X-axis limit sensor error	Correct the speed so as not to exceed the range. Replace the sensor
E302	Y-axis limit sensor error	Correct the speed so as not to exceed the range. Replace the sensor
E303	Z-axis limit sensor error	Correct the speed so as not to exceed the range. Replace the sensor
E304	R-axis limit sensor error	Correct the speed so as not to exceed the range. Replace the sensor
E314	X-axis command position error	Correct the speed so as not to exceed the range. Correct the target point
E315	Y-axis command position error	Correct the speed so as not to exceed the range. Correct the target point
E316	Z-axis command position error	Correct the speed so as not to exceed the range. Correct the target point
E317	R-axis command position error	Correct the speed so as not to exceed the range. Correct the target point

### 4-3 When Memory Card (RK Card) is Used

The operational flow starting from turning on the main power of the machine until the programmed operation or teaching is started, is shown as follows. Causes and countermeasures when trouble occurs in the respective state from 1) to 9) are shown on the next page. Use these tables for troubleshooting.

There may be a case when an error number is displayed on the teaching pendant. When “EEE” and “error number” appear alternately, it indicates that the trouble is the robot error. The robot errors which can occur in the ROBOKIDS are shown as follows. When any error number other than those listed below appears, consult your Sony dealer for more details.

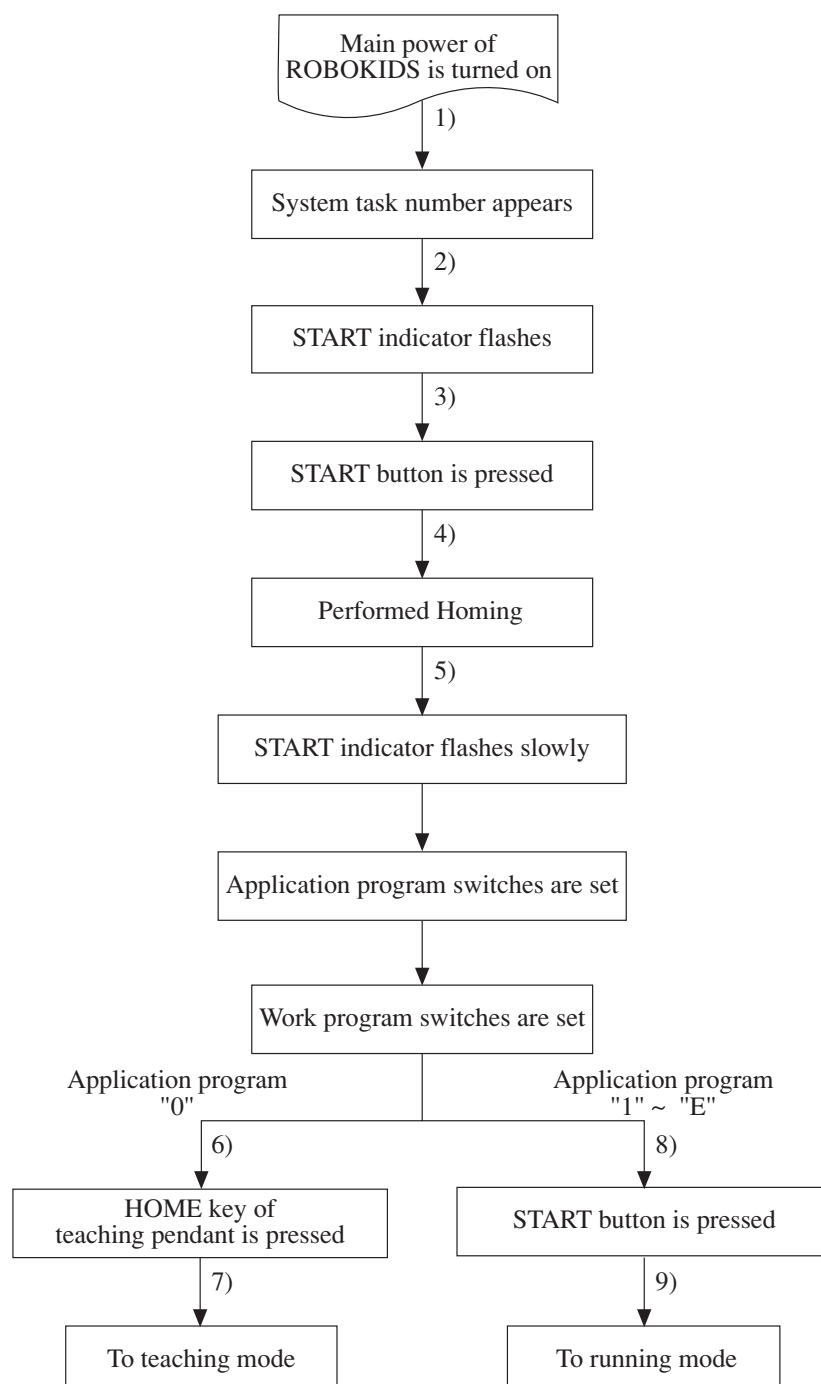

### Fault-Finding Chart of 1)

Symptoms	Causes	Solutions
The simple operation teaching pendant keeps displaying “666”	OFF LINE is selected	Connect the SYSRUN Set the machine system to “ONLINE” from the TP of the SRX
	Internal PC board is defective	Exchange the internal PC board
“E01” appears on the simplified TP.	Card is not inserted	Insert the memory card securely
“E02” appears on the simplified TP.	The card has no program	Insert a memory card in which program is stored
	The CAST specification setting is set to NO	Set the CAST specification setting to “YES” from the TP of the SRX
The main power cannot be turned on.	The main AC power is not turned on	Connect the AC main power
		Exchange the POWER switch
The stop indicator keeps turning on.	The POWER switch is broken	Release the lock
	The STOP button is kept locked. (Including the teaching pendant)	
	The external stop signal is being connected	Release the external emergency stops Alternatively, short pin-1 and pin-2 of the external switch connector

### Fault-Finding Chart of 2)

Symptoms	Causes	Solutions
START indicator does not illuminate	START indicator is defective	Replace the START indicator
START indicator keeps flashing	START button has the short circuit	Replace the START button
	External START switch has the short circuit	Replace the external START button

### Fault-Finding Chart of 3)

Symptoms	Causes	Solutions
START button does not function	START button is defective	Replace the START button

### Fault-Finding Chart of 4)

Symptoms	Causes	Solutions
“E07” appears on display	Returning home failed	Start operation from the very beginning
Machine movement does not stop (It moves in the reverse direction.)	Sensor cable is defective	Confirm the sensor cable connection
	Controller data is abnormal	Correct the controller data from TP of the SRX

**Fault-Finding Chart of 5)**

Symptoms	Causes	Solutions
“E08” appears on display	TYPESET failed	Turn on the main power of the machine system and start operation from the very beginning
“E09” appears on display	START failed	Turn on the main power of the machine system and start operation from the very beginning

**Fault-Finding Chart of 6) or 7) or 8)**

Symptoms	Causes	Solutions
START indicator keeps flashing	Application program switch is defective	Replace the application program switch
“HOME” key does not function	Teaching pendant is defective	Replace the teaching pendant
“E10” appears on display during teaching	A point outside the work envelope is specified by INSERT/DELETE	Specify the point inside the area and try again
“E11” appears on display during teaching	The target coordinate of copy has exceeded the work envelope during COPY.	Perform COPY so as not to exceed the work envelope
“E12” appears on display during teaching	Number of point storage capacity of the target point of copy is insufficient during COPY	Perform COPY within the storage capacity of point
“E30” appears on display	Step-out of the X-axis in the opposite direction to home position has occurred	Check weight of the tool and check also if there is any interfering obstacles around the point
“E31” appears on display	Step-out of the X-axis in the home position direction has occurred	Check weight of the tool and check also if there is any interfering obstacles around the point
“E32” appears on display	Step-out of the Y-axis in the opposite direction to home position has occurred	Check weight of the work and check also if there is any interfering obstacles around the point
“E33” appears on display	Step-out of the Y-axis in the home position direction has occurred	Check weight of the work and check also if there is any interfering obstacles around the point
“E34” appears on display	Step-out of the Z-axis in the opposite direction to home position has occurred	Check weight of the tool and check also if there is any interfering obstacles around the point
“E35” appears on display	Step-out of the Z-axis in the home position direction has occurred	Check weight of the tool and check also if there is any interfering obstacles around the point
“E36” appears on display	Step-out of the R-axis in the opposite direction to home position has occurred	Check weight of the tool and check also if there is any interfering obstacles around the point
“E37” appears on display	Step-out of the R-axis in the home position direction has occurred	Check weight of the tool and check also if there is any interfering obstacles around the point
The machine does not operate normally	Teaching has not been done correctly	Perform teaching again.
	Machine is loaded with excessive weight	Refer to section “1-3-1 Machine specifications”.
	Cover is contacting with moving object	Correct the cover position
	Dropped parts such as screws are choking.	Remove anything dropped
	External unit is defective	Repair or replace the external unit
	External noise is affecting	Remove the source of noise

**The belt tension adjustment**

Consult your Sony dealer from which you purchased the machine or the nearest Sony FA offices for the actual adjustment of the belt tension.

# Trouble Check Sheet

If a trouble occurs, check the following items before contacting your Sony dealer or the nearest Sony FA offices.

- 1) Name of dealer from which you purchased the ROBOKIDS  
Company name : \_\_\_\_\_ Person in charge : \_\_\_\_\_ Tel: \_\_\_\_\_
- 2) What is the serial number of your ROBOKIDS? (It is marked on the sticker of the rear cover.)  
M No. \_\_\_\_\_ R No. \_\_\_\_\_
- 3) What type of memory card are you using ? (It is marked on the memory card.)  
TYPE \_\_\_\_\_ NAME \_\_\_\_\_
- 4) When did the trouble occur?
  1. Has the trouble occurred since you purchased the ROBOKIDS?
  2. The ROBOKIDS ran normally, but then troubles suddenly occurred.
  3. The machine has gradually become worse.
  4. Others \_\_\_\_\_In case of 1, what was the condition of the ROBOKIDS?
  1. How was the condition during initial operation after purchase?
  2. The main power has not been turned on for a long time (for \_\_\_\_\_ days).
  3. The main power has not been turned on for a short time (for \_\_\_\_\_ days).
  4. What was the condition when the main power was turned on?
- 5) Describe the details of the trouble (such as error code, etc.).  
\_\_\_\_\_  
\_\_\_\_\_  
\_\_\_\_\_
- 6) Compared with normal operation, at what timing does the error occur?  
\_\_\_\_\_  
\_\_\_\_\_
- 7) If you have two or more ROBOKIDS, compare them. What are the results of the comparison?  
\_\_\_\_\_
- 8) What happens if you replace parts (such as the memory card)?  
\_\_\_\_\_
- 9) Is there any noise source near the ROBOKIDS? Yes / No
- 10) What is the condition of the ROBOKIDS at present?
  - The ROBOKIDS is not being used.
  - The ROBOKIDS is still being used.
- 11) Customer  
Company name : \_\_\_\_\_ Department : \_\_\_\_\_ Person in charge : \_\_\_\_\_  
Tel : \_\_\_\_\_  
Fax : \_\_\_\_\_

Fill in the above items, and send this form to your Sony dealer or the nearest Sony FA offices by fax.

## 5. Repair Parts Lists

### 5-1 ROBOKIDS Body

Descriptions	Part No.	Remarks
TASK board	A-8338-047-A	Built-in board "Small"
BASE board	A-8338-048-A	Built-in board "Large"
Battery	1-528-932-11	
DC switching power supply ZWS30-5/J	1-468-348-11	For DC 5 V
DC switching power supply ZWS150PF-24/J	1-468-349-11	For DC 24 V
Circuit protector	1-576-271-11	POWER switch
Fan harness	1-959-099-11	Inside the ROBOKIDS
Self-illuminating stop switch	1-572-977-11	Operation box
Self-illuminating stop switch	1-771-539-11	Operation box
Digital switch	1-771-538-11	Operation box
X-axis motor	1-763-186-11	
Y-axis motor	1-763-186-11	
X-axis home position sensor harness	1-959-094-11	
Y-axis home position sensor harness	1-959-095-11	
X-axis liner guide	4-760-637-01	
Y-axis liner guide	4-760-638-01	
X-axis timing belt	4-760-635-02	
Y-axis timing belt	4-760-636-02	
Media	4-761-607-01	Air filter
Cable harness	1-959-100-11	
Electrical fitting assembly	A-8338-050-A	
Control block assembly	A-8338-046-A	
Y-axis assembly	A-8336-316-A	
X-axis assembly	A-8336-315-A	

### 5-2 Z-axis Unit

Descriptions	Part No.	Remarks
Z-axis motor	1-763-187-11	
Z-axis home position sensor harness	1-959-096-11	
Z-axis linear guide	4-760-643-01	
Z-axis timing belt	4-760-641-01	Long
Z-axis relay cable harness	1-790-017-11	
Z-axis timing belt	4-760-642-01	Short
Bearing	4-760-650-01	
Mechanism block assembly	A-8336-325-A	

### 5-3 Z/R-axis Unit

---

Descriptions	Part No.	Remarks
Z-axis motor	1-763-187-11	
R-axis motor	1-763-187-11	
Z-axis home position sensor harness	1-959-101-11	
R-axis home position sensor harness	1-959-097-12	
Spline ball screw	4-760-605-01	
Z-axis timing belt	4-760-645-01	
R-axis timing belt	4-760-644-01	
Z/R-axis relay cable harness	1-959-098-12	
Bearing	4-760-650-01	
Mechanism block assembly	A-8336-314-A	

## 6. Appendix

### ■ User Input/Output Specifications of USER I/O Connector Input

Connector pin No.	I/O names in terms of software	Contents	
		RK card specification (including semi-programmable specification)	Full-open programmable specification
3	SI1	SYSRUN	
37	SI2	Reserved by system (User cannot use it.)	
4	SI3	Reserved by system (User cannot use it.)	
38	SI4	Reserved by system (User cannot use it.)	
5	SI5	Reserved by system (User cannot use it.)	
39	SI6	Reserved by system (User cannot use it.)	
6	SI7	Reserved by system (User cannot use it.)	
40	SI8	Reserved by system (User cannot use it.)	
7	I1	START	User input
41	I2	RETRUN	User input
8	I3	Work program No. 1	User input
42	I4	Work program No. 2	User input
9	I5	Work program No. 4	User input
43	I6	Work program No. 8	User input
10	I7	Application program No. 1	User input
44	I8	Application program No. 2	User input
11	I9	Application program No. 4	User input
45	I10	Application program No. 8	User input
12	I11	Error reset	User input
46	I12	*	User input
13	I13	*	User input
47	I14	*	User input
14	I15	*	User input
48	I16	*	User input
15	I17	*	User input
49	I18	*	User input
16	I19	*	User input
50	I20	*	User input
17	I21	*	User input
51	I22	*	User input

\* The allocation at I12 to I22 differs depending upon applications. Refer to the Operation Manual of memory card (RK card) for more details.

#### NOTE

*The switch SI1 (SYSRUN) must always be connected. The ROBOKIDS cannot be operated unless the SI1 is turned on.*

*Turn on or off SI1 as required. (Refer to page 2-6.)*



## Output

Connector pin No.	I/O names in terms of software	Contents	
		RK card specification (including semi-programmable specification)	Full-open programmable specification
20	SO1	EMG-OUT, stop switch, stop status output	
54	SO2	ERROR, robot error signal	
21	SO3	Reserved by system (User cannot use it.)	
55	SO4	Drive servo ON signal	
22	SO5	ONLINE signal	
56	SO6	Reserved by system (User cannot use it.)	
23	SO7	Reserved by system (User cannot use it.)	
57	SO8	Reserved by system (User cannot use it.)	
24	L1	End of cycle output	User output
58	L2	Standby output	User output
25	L3	Error output	User output
59	L4	During operation output	User output
26	L5	Unloading position output (during line mode)	User output
60	L6	*	User output
27	L7	*	User output
61	L8	*	User output
28	L9	*	User output
62	L10	*	User output
29	L11	*	User output
63	L12	*	User output
30	L13	*	User output
64	L14	*	User output
31	L15	*	User output
65	L16	*	User output
32	L17	*	User output
66	L18	*	User output
33	L19	*	User output
67	L20	*	User output
34	L21	*	User output
68	L22	*	User output

\* The allocation at L6 to L22 differs depending upon applications. Refer to the Operation Manual of memory card (RK card) for more details.

### ■ Pin assignment

2	4	6	8	~	30	32	34	
1	3	5	7	9	~	29	31	33
	36	38	40	42	~	64	66	68
35	37	39	41	~	63	65	67	

## ■ Specifications of the Connected I/O (Used only in the semi-programmable specifications and the full open programmable specifications)

### Input

I/O names in terms of software	Contents
I23	START button (White button of operation box)
I24	RETURN button (To be connected from the rear SAFETY connector by user)
I25	Work program No. 1 (First digit of the PROGRAM switch of the operation box (1))
I26	Work program No. 2 (First digit of the PROGRAM switch of the operation box (2))
I27	Work program No. 4 (First digit of the PROGRAM switch of the operation box (4))
I28	Work program No. 8 (First digit of the PROGRAM switch of the operation box (8))
I29	Application program No. 1 (Second digit of the PROGRAM switch of the operation box (1))
I30	Application program No. 2 (Second digit of the PROGRAM switch of the operation box (2))
I31	Application program No. 4 (Second digit of the PROGRAM switch of the operation box (4))
I32	Application program No. 8 (Second digit of the PROGRAM switch of the operation box (8))

### Output

I/O names in terms of software	Contents
L23	START LED (White indicator)
L24	Stop LED (Red indicator)
L25	RETURN indicator (To be connected from the rear SAFETY connector by user)
L26	Stop indicator (To be connected from the rear SAFETY connector by user)
L27	The barrier signal from the rear SAFETY connector becomes valid when the barrier is enabled.
L28	User cannot use it.
L29	User cannot use it.

## ■ User external power supply connector

Power connector for I/O	
Pin No.	Name
1	24 V
2	GND

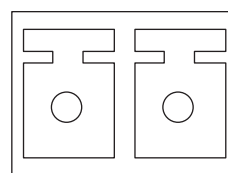

1 2

## ■ Connector for Debug Station

Pin No.	Signal	Contents
1	FG	Frame ground
2	TP-RXD	Connector for SRX teaching pendant (Receive data)
3	TP-TXD	Connector for SRX teaching pendant (Transmit data)
4	TP-CTS	Connector for SRX teaching pendant (Clear to send)
5	TP-RTS	Connector for SRX teaching pendant (Request to send)
6	TP-DTR	Connector for SRX teaching pendant (Data terminal ready)
7	C GND	Signal ground
8	SIO-DSR	Connector for program transfer (Data set ready)
9	SIO-RXD	Connector for program transfer (Receive data)
10	C GND	Signal ground
11	NC	–
12	C GND	Signal ground
13	SIO-CTS	Connector for program transfer (Clear to send)
14	NC	–
15	SIO-RTS	Connector for program transfer (Request to send)
16	EXS5	Connector for SRX teaching pendant (Emergency stop)
17	EXS2	Connector for SRX teaching pendant (Emergency stop)
18	/TP CN1	SRX teaching pendant is connected or not
19	NC	–
20	TP-DSR	Connector for SRX teaching pendant (Data set ready)
21	SIO-TXD	Connector for program transfer (Transfer data)
22	PC05V	+5V for SRX teaching pendant
23	SIO-DTR	Connector for program transfer (Data terminal ready)
24	C GND	Signal ground
25	PC05V	+5V for SRX teaching pendant

Type : DBLC-J25SAF-10L9      Manufacturer : JAE  
 Applicable plug : DBSP-JB25PF      Manufacturer : JAE  
 Applicable shell : DB-C8-J10-F4-1      Manufacturer : JAE

## ■ Connector for Operation Box

Pin No.	I/O names in terms of software	Contents
1	I25	Work program No. 1 (First digit of the PROGRAM switch (1))
2	L23	START LED
3	L24	Stop LED
4	–	0 V
5	I32	Application program No. 8 (Second digit of the PROGRAM switch (8))
6	I23	START button
7	–	Stop button
8	–	Stop button
9	–	24 V
10	I31	Application program No. 4 (Second digit of the PROGRAM switch (4))
11	I26	Work program No. 2 (First digit of the PROGRAM switch (2))
12	I27	Work program No. 4 (First digit of the PROGRAM switch (4))
13	I28	Work program No. 8 (First digit of the PROGRAM switch (8))
14	I29	Application program No. 1 (Second digit of the PROGRAM switch (1))
15	I30	Application program No. 2 (Second digit of the PROGRAM switch (2))

Type : 17HE-13150-73

Manufacturer : DDK

Applicable plug : 17HE-23150-CD8A

Manufacturer : DDK

Applicable shell : 17H-7PCR-102

Manufacturer : DDK

## ■ RS232C connector (Rear Panel)

Pin No.	Signal	Contents
1	NC	-
2	TXD	Transmit data
3	RXD	Receive data
4	DSR	Data set ready
5	SG	Signal ground
6	DTR	Data terminal ready
7	CTS	Clear to send
8	RTS	Request to send
9	NC	-

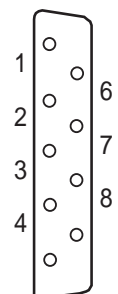

Type : CDS-3109-0122

Manufacturer : SMK

Applicable plug : 17JE-23090-02

Manufacturer : DDK

Applicable shell : 17JE-09H-1A

Manufacturer : DDK

## ■ SAFETY Connector

Pin No.	Signal	Contents
1	24V	+24 V
2	SA START OUT	RETURN indicator
3	SA STOP OUT	Stop indicator
4	STOP RELAY OUT (C)	Stop output common
5	STOP RELAY OUT (NO)	Stop output (NO)
6	STOP RELAY OUT (NC)	Stop output (NC)
7	0V	–
8	FG	FG (Shielded wire, etc.)
9	SA RETURN IN	RETURN switch
10	SA Stop IN (C)	Stop switch
11	SA Stop IN (NC)	Stop switch
12	BAR (C)	Barrier (safety door, etc.)
13	BAR (NC)	Barrier (safety door, etc.)
14	Stop BAR RELEASE	External stop switch and barrier are enabled
15	0V	–

Type : DA-J15PF1L9

Manufacturer : JAE

Applicable plug : DA-15PF-N

Manufacturer : JAE

Applicable shell : DA-C4-J10

Manufacturer : JAE

## ■ Connector for ZR-axis Cable

Pin No.	Signal	Contents
1	FG	Frame ground
2	ZR_COM	Unit signal common (GND)
3	Z_DET	Z-unit signal
4	ZR_DET	ZR-unit signal
5	Z_24V	DC 24 V for Z sensor
6	Z_LIM	Z-sensor signal
7	Z_GND	Ground for Z-sensor
8	Z_A	Z-axis phase A signal
9	Z_B_C	Z-axis -phase B common (DC 24 V)
10	Z_/B	Z-axis phase/B
11	R_A	R-axis phase A
12	R_B_C	Z-axis -phase B common (DC 24 V)
13	R_/B	R-axis phase/B
14	BRK+	Brake (+, DC 24 V)
15	BRK-	Brake (-, ground)
16	R24V	DC 24 V for R sensor
17	R_LIM	R sensor signal
18	R_GND	Ground for R sensor
19	FG	Frame ground
20	Z_A_C	Z-axis phase A common (DC 24 V)
21	Z_/A	Z-axis phase /A
22	Z_B	Z-axis phase B
23	R_A_C	R-axis phase A common (DC 24 V)
24	R_/A	R-axis phase/A
25	R_B	R-axis phase B

Model : DBLC-J25SAF-10L9      Manufacturer : JAE  
 Applicable plug : DB-25PF-IN      Manufacturer : JAE  
 Applicable shell : DB-C4-J11      Manufacturer : JAE

**Supply Period of Repair Parts**

The functional repair parts (parts needed to maintain product performance) of this machine will be supplied for up to seven years in principle after production is discontinued.

Because it may be possible to repair the machines depending upon the location of the problem even after this period, consult the service or sales representative from where you purchased the machine.

**[ Singapore ]****Sony Electronics (Singapore) Pte. Ltd**

TEL : 8615858

FAX : 8621521

**[ Europe ]****Sony Wega Produktions GmbH****Production Technology Division Europe**

TEL : +49 (0)711 5858-420

FAX : +49 (0)711 574153

**[ Japan ]****Sony Manufacturing Systems Corporation,****FA service Department.**

TEL : 0480-23-1956

FAX : 0480-23-1706

---

1st Edition November, 1998  
3rd Edition October, 2001



